

Votre distributeur : RUVAULT Design



Professional Refrigeration

Tél (France) : +33 (0)6 60 52 24 38

contact@grouparuault.com

CATALOGO  
2020

[contact@groupe-ruault.com](mailto:contact@groupe-ruault.com)

KNORR-BREMSE

PROFESSIONNELLE

INNOVATION

Tel (France) : +33 (0)6 60 52 24 38

Votre distributeur : RUAULT Design



Professional Refrigeration

2020, una tappa miliare nella storia di UCINQUE. UCINQUE cambia la sua veste grafica. Il passaggio a colori scuri, un nuovo logo, è il frutto di una scelta dettata dal rapido progresso dell'azienda che, in soli cinque anni, è arrivata a rappresentare un punto di riferimento nel mondo della Refrigerazione Professionale. I nuovi colori sociali, la nuova geometria del logo tendono infatti a comunicare immediatamente le due caratteristiche salienti di UCINQUE, cura del Design ed attenzione verso la continua Ricerca Tecnologica. Ma al di là dell'immagine, della veste grafica, le caratteristiche di U5 rimangono invariate:

CONOSCENZA
PASSIONE
INNOVAZIONE

Queste, secondo noi, le caratteristiche per competere in un mercato in costante mutamento.

2020, a milestone in U5's history. The way to communicate corporate style changes. Shifting to dark colours and to a new logo is the natural outcome of a fast-track growth for an organization that in just five years' has been acknowledged as a benchmark in the Professional Refrigeration arena. New colours together with the new geometry of the logo are meant to signify the two distinctive traits of UCINQUE: unceasing attention to Design and Technology drive. Beyond corporate style, UCINQUE features remain consistent:

KNOWLEDGE
PASSION
INNOVATION

In our opinion, these are the needful qualities to win competition in an ever-evolving market.



# I NOSTRI PRODOTTI

U5 punta alla massima soddisfazione del mercato. Per tale motivo U5 propone attrezzature refrigerate per ciascuno dei quattro canali principali, Beverage, Ice Cream, Supermarket e Catering. Ai banchi prodotti in Italia nello stabilimento di Occimiano (contrassegnati con il logo MADE IN ITALY) affianchiamo frigo prodotti dai nostri selezionati partner Europei ed Extraeuropei. In ogni caso il Team tecnico di U5 lavora per il continuo miglioramento di tutti i suoi modelli per garantire il minor impatto ambientale e bassi consumi energetici. Negli impianti e nelle schiume di isolamento il nostro output utilizza esclusivamente Gas HC, ossia gas naturali non dannosi per l'ambiente. Abbiamo iniziato ad utilizzare plastiche riciclate totalmente riciclabili per molteplici particolari (Es. cornici, cruscotti, ecc.). Questo processo non può fermarsi, la Terra è l'eredità da lasciare ai nostri figli.

## OUR PRODUCTS

U5 aims for maximum market satisfaction, in fact our refrigerated equipment fleet covers each of the four main channels: Beverage, Ice Cream, Supermarket and Catering. We offer refrigerated units manufactured at our Occimiano plant ("MADE IN ITALY" marked) and in parallel cabinets manufactured by our selected European and non-European partners. What is more, U5 R&D team work to refine models so as to achieve the lowest environmental impact and energy consumption level. For all our products HC gas is used in the insulation systems and foams, as natural gases do not harm the environment. We have also turned to fully recyclable plastics for several cabinet parts (eg. frames, dashboards, etc.). This process will go on: planet Earth is the legacy to be inherited by our offspring.

BEVERAGE

ICE CREAM

SUPERMARKET

CATERING



contact@groupe-ruault.com

# INDICE • INDEX

## Beverage

CX .....	7
CAN .....	10
POP .....	12
RB .....	12
SELF BAR .....	15
FV .....	18
KRYO .....	25
FV 110 S .....	32
CW .....	33
WINE CLASS .....	38
CW L .....	40

## Ice cream

CUBE .....	43
IQ .....	44
POP .....	46
JOKER .....	49
KAPPA .....	50
CIS .....	52
VINTAGE .....	55
BMAX .....	57
KRYO NV .....	62
FROST .....	63
VERTICAL VINTAGE .....	81
GLAMOUR TOWER .....	83
TWIN 40 .....	86
TRECARAPINE .....	87
VIA VENETO .....	88
VIA VENETO COMBI .....	91
VINTAGE SCOOPING .....	94
EVOQUE .....	96

## Supermarket

SYSON PLUS .....	98
GT EVO .....	101
GT EVO HGD .....	104
PROMO 75 .....	107

## catering

CHF .....	109
GOURMET .....	112
AC P .....	114
AC N .....	117

servizi - services .....	120
--------------------------	-----

DIMENSIONI e PESI - DIMENSIONS AND WEIGHTS .....	121
--	-----

# BEVERAGE

[contact@groupe-ruault.com](mailto:contact@groupe-ruault.com)

Tél (France) : +33

(0)6 60 52 24 38

Votre distributeur : RUAULT Design



# CX 50

+2°/+10° C



L x P x H: 495 x 450 x 495 mm  
Area visibile: 0,144 mq • Classe climatica: 4  
Consumo energetico (24h): 0,9 kW  
Watt: 80 • Refrigerazione: Statica  
Capacità lorda: 56 lt • Capacità netta: 45 lt  
Termostato: Meccanico • Sbrinamento: Manuale  
Termometro: Meccanico • Gas: R600a  
Luce LED con interruttore • 4 piedini regolabili  
Colore esterno: Grigio silver  
1 griglia (410 x 250 mm)

W x D x H: 495 x 450 x 495 mm  
Display area: 0,144 sqm • Climatic class: 4  
Energy consumption (24h): 0,9 kW  
Watt: 80 • Refrigeration: Static  
Gross capacity: 56 lt • Net capacity: 45 lt  
Thermostat: Mechanic • Defrosting: Manual  
Thermometer: Mechanic • Gas: R600a  
LED light with switch • 4 adjustable feet  
Body colour: Silver Grey  
1 shelf (410 x 250 mm)



14 x 33 cl



11 x 66 cl



## A RICHIESTA • OPTIONAL

Grafica su mobile e/o vetro frontale  
Graphic on body and/or front glass

# CX 68

+2°/+10° C

Votre distributeur : RUVAULT Design  
Tél (France) : +33 (0)6 50 52 24 38



Luce interna LED  
Internal LED light

L x P x H: 495 x 450 x 670 mm  
Area visibile: 0,20 mq • Classe climatica: 4  
Consumo energetico (24h): 1,0 kW  
Watt: 85 • Refrigerazione: Statica  
Capacità lorda: 76 lt • Capacità netta: 65 lt  
Termostato: Meccanico • Sbrinamento: Manuale  
Termometro: Meccanico • Gas: R600a  
Luce LED con interruttore • 4 piedini regolabili  
Colore esterno: Grigio silver  
1 griglia (410 x 176 mm) + 1 (410 x 250 mm)

W x D x H: 495 x 450 x 670 mm  
Display area: 0,20 sqm • Climatic class: 4  
Energy consumption (24h): 1,0 kW  
Watt: 85 • Refrigeration: Static  
Gross capacity: 76 lt • Net capacity: 65 lt  
Thermostat: Mechanic • Defrosting: Manual  
Thermometer: Mechanic • Gas: R600a  
LED light with switch • 4 adjustable feet  
Body colour: Silver Grey  
1 shelf (410 x 200 mm) + 1 (410 x 250 mm)



30 x 33 cl



12 x 66 cl



## A RICHIESTA • OPTIONAL

Grafica su mobile e/o vetro frontale  
Graphic on body and/or front glass

# CX 98

+2°/+10° C



Luce interna LED  
Internal LED light

BEVERAGE  
ESPOSITORI DA BANCO • COUNTER TOP COOLERS

L x P x H: 495 x 450 x 825 mm  
Area visibile: 0,27 mq • Classe climatica: 4  
Consumo energetico (24h): 1,10 kW  
Watt: 90 • Refrigerazione: Statica  
Capacità lorda: 106 lt • Capacità netta: 95 lt  
Termostato: Meccanico • Sbrinamento: Manuale  
Termometro: Meccanico • Gas: R600a  
Luce LED con interruttore • 4 piedini regolabili  
Colore esterno: Grigio silver  
1 griglia (400 x 176 mm) + 2 (410 x 250 mm)

W x D x H: 495 x 450 x 825 mm  
Display area: 0,27 sqm • Climatic class: 4  
Energy consumption (24h): 1,10 kW  
Watt: 90 • Refrigeration: Static  
Gross capacity: 106 lt • Net capacity: 95 lt  
Thermostat: Mechanic • Defrosting: Manual  
Thermometer: Mechanic • Gas: R600a  
LED light with switch • 4 adjustable feet  
Body colour: Silver Grey  
1 shelf (400 x 176 mm) + 2 (410 x 250 mm)



40 x 33 cl



24 x 66 cl



## A RICHIESTA • OPTIONAL

Grafica su mobile e/o vetro frontale  
Graphic on body and/or front glass

# CAN 50

+2°/+10° C

Votre distributeur : RUVAULT Design



Apertura coperchio  
*Lid opening*



Ruote pivotanti  
*Pivoting wheels*

Ø x H: 442 x 865 mm  
Area visibile: 0,096 mq  
Classe climatica: 4 • Watt: 50  
Consumo energetico (24h): 0,6 kW  
Capacità lorda: 50 lt • Capacità netta: 48 lt  
Termostato: Meccanico • Sbrinamento: Manuale  
Gas: R600a • Refrigerazione: Statica  
4 ruote pivotanti  
Colore esterno: Bianco

Ø x H: 442 x 865 mm  
Display area: 0,096 smt  
Climatic class: 4 • Watt: 50  
Energy consumption (24h): 0,6 kW  
Gross capacity: 50 lt • Net capacity: 48 lt  
Thermostat: Mechanic • Defrosting: Manual  
Gas: R600a • Refrigeration: Static  
4 Pivoting wheels  
Body colour: White



**A RICHIESTA • OPTIONAL**

Grafica su mobile, vetro superiore  
*Graphic on body, top glass*

# CAN 65

+0°/+7° C

Votre distributeur : RUAULT Design

FRIGOPER BEVANDE • CHEST COOLERS



Griglia divisoria  
Divider grid



Apertura coperchio  
Lid opening



Avvolgicavo  
Cable reel



Ruote pivotanti  
Pivoting wheels



Ø x H: 548 x 960 mm  
Area visibile: 0,124 mq  
Classe climatica: 4 • Watt: 150  
Consumo energetico (24h): 1,70 kW  
Capacità lorda: 76 lt • Capacità netta: 61 lt  
Termostato: Elettronico • Sbrinamento: Automatico  
Gas: R600a • Refrigerazione: Ventilata  
2 ruote pivotanti + 2 ruote pivotanti con freno  
Colore esterno: Bianco

Ø x H: 548 x 960 mm  
Display area: 0,124 smt  
Climatic class: 4 • Watt: 150  
Energy consumption (24h): 1,70 kW  
Gross capacity: 76 lt • Net capacity: 61 lt  
Thermostat: Electronic • Defrosting: Automatic  
Gas: R600a • Refrigeration: Ventilated  
2 pivoting wheels + 2 pivoting wheels with brake  
Body colour: White



## A RICHIESTA • OPTIONAL

Grafica su mobile, vetro superiore  
Graphic on body, top glass

# POP 365 P

+2°/+10° C



Cerniera con frizione  
Hinge with clutch



Guarnizione removibile  
Removable gasket



Luce interna LED  
Internal LED light

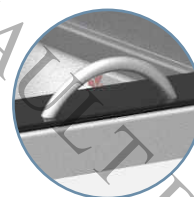

maniglia in metallo  
Metal handle

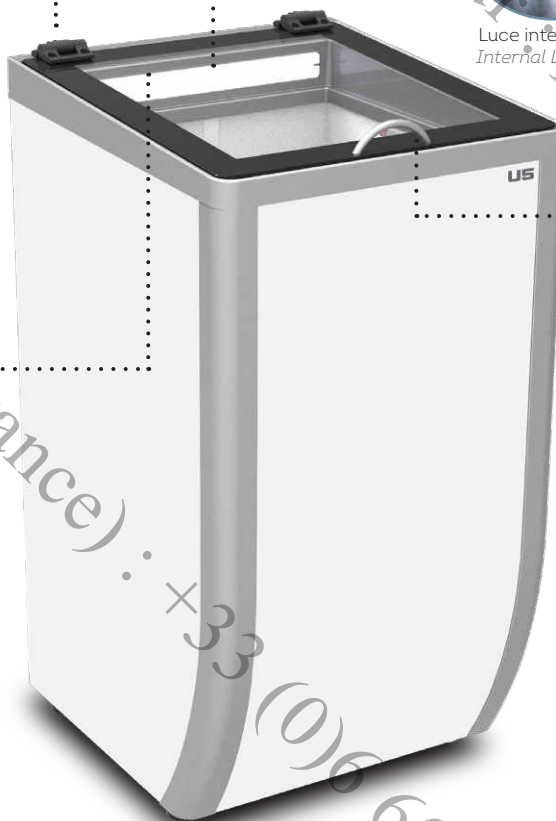

L x P x H: 505 x 555 x 980 mm  
Area visibile: 0,144 mq  
Classe climatica: 4 • Refrigerazione: Statica  
Consumo energetico (24h): 2,52 kW  
Capacità lorda: 63 lt • Capacità netta: 57 lt  
Termostato: Elettronico • Sbrinatorio: Manuale  
Termometro: Digitale • Gas: R600a  
Luce LED interna • 4 piedini regolabili  
Colore esterno: Bianco e Grigio

W x D x H: 505 x 555 x 980 mm  
Display area: 0,144 smt  
Climatic class: 4 • Refrigeration: Static  
Energy consumption (24h): 2,52 kW  
Gross capacity: 63 lt • Net capacity: 57 lt  
Thermostat: Electronic • Defrosting: Manual  
Thermometer: Digital • Gas: R600a  
Internal LED light • 4 adjustable feet  
Body colour: White and Grey



**A RICHIESTA • OPTIONAL**  
Grafica su mobile, vetro superiore  
Graphic on body, top glass

*Duerighedesign*

# RB 300

+2°/+10° C



Serratura con chiave  
Key lock

L x P x H: 1090 x 690 x 860 mm  
Classe climatica: 4 • Watt: 165  
Capacità lorda: 249 lt • Capacità netta: 226 lt  
Termostato: Meccanico • Sbrinamento: Manuale  
Termometro: Meccanico  
Gas: R600a • Refrigerazione: Statica  
Serratura con chiave • 4 rullini unidirezionali  
Colore esterno: Bianco

W x D x H: 1090 x 690 x 860 mm  
Climatic class: 4 • Watt: 165  
Gross capacity: 249 lt • Net capacity: 226 lt  
Thermostat: Mechanic • Defrosting: Manual  
Thermometer: Mechanic  
Gas: R600a • Refrigeration: Static  
Key lock • 4 rollers  
Body colour: White



## A RICHIESTA • OPTIONAL

Grafica su mobile e/o coperchio superiore • Kit ruote  
Graphic on body and/or top cover • Wheel kit

# RB 400

+2°/+10° C

Votre distributeur : RUVAULT Design



Serratura con chiave  
Key lock



Tel (France) : +33 (0)6 60 52 24 38

L x P x H: 1320 x 690 x 860 mm  
Classe climatica: 4 • Watt: 250  
Capacità lorda: 320 lt • Capacità netta: 297 lt  
Termostato: Meccanico • Sbrinamento: Manuale  
Termometro: Meccanico  
Gas: R600a • Refrigerazione: Statica  
Serratura con chiave • 4 rullini unidirezionali  
Colore esterno: Bianco

W x D x H: 1320 x 690 x 860 mm  
Climatic class: 4 • Watt: 250  
Gross capacity: 320 lt • Net capacity: 297 lt  
Thermostat: Mechanic • Defrosting: Manual  
Thermometer: Mechanic  
Gas: R600a • Refrigeration: Static  
Key lock • 4 rollers  
Body colour: White

contatti@groupe-ruault.com



**A RICHIESTA • OPTIONAL**

Grafica su mobile e/o coperchio superiore • Kit ruote  
Graphic on body and/or top cover • Wheel kit

# SELF BAR 1

+2°/+10° C



L x P x H: 600 x 500 x 900 mm  
 Area visibile: 0,36 mq  
 Classe climatica: 4 • Gas: R600a  
 Consumo energetico (24h): 0,9 kW  
 Capacità lorda: 112 lt • Capacità netta: 104 lt  
 Termostato: Elettronico • Sbrinamento: Automatico  
 Termometro: Elettronico  
 Refrigerazione: Statica con agitatore  
 Luce LED con interruttore • Serratura con chiave  
 4 piedini regolabili • Colore esterno: Nero  
 2 griglie (495 x 320 mm)

W x D x H: 600 x 500 x 900 mm  
 Display area: 0,36 smt  
 Climatic class: 4 • Gas: R600a  
 Energy consumption (24h): 0,9 kW  
 Gross capacity: 112 lt • Net capacity: 104 lt  
 Thermostat: Electronic • Defrosting: Automatic  
 Thermometer: Electronic  
 Refrigeration: Static with fan  
 LED light with switch • Key lock  
 4 Adjustable feet • Body colour: Black  
 2 shelves (495 x 320 mm)



# SELF BAR 2

+2°/+10° C



Serratura con chiave  
Key lock



Luce interna LED  
Internal LED light



Termostato elettronico  
Electronic thermostat

L x P x H: 900 x 500 x 900 mm  
Area visibile: 0,538 mq  
Classe climatica: 4 • Gas: R600a  
Consumo energetico (24h): 1,25 kW  
Capacità lorda: 175 lt • Capacità netta: 168 lt  
Termostato: Elettronico • Sbrinamento: Automatico  
Termometro: Elettronico  
Refrigerazione: Statica con agitatore  
Luce LED con interruttore • Serratura con chiave  
4 piedini regolabili • Colore esterno: Nero  
4 griglie (375 x 345 mm)

W x D x H: 900 x 500 x 900 mm  
Display area: 0,538 smt  
Climatic class: 4 • Gas: R600a  
Energy consumption (24h): 1,25 kW  
Gross capacity: 175 lt • Net capacity: 168 lt  
Thermostat: Electronic • Defrosting: Automatic  
Thermometer: Electronic  
Refrigeration: Static with fan  
LED light with switch • Key lock  
4 Adjustable feet • Body colour: Black  
4 shelves (375 x 345 mm)



224 x 33 cl



120 x 66 cl



40 x 1,5 lt



Automatic Defrost



ECO Friendly



Made by  
US  
Partners



GAS "HC"  
R600a



# SELF BAR 3

+2°/+10° C



Serratura con chiave  
Key lock



Luce interna LED  
Internal LED light



Termostato elettronico  
Electronic thermostat



L x P x H: 1335 x 500 x 900 mm  
Area visibile: 0,835 mq  
Classe climatica: 4 • Gas: R600a  
Consumo energetico (24h): 1,50 kW  
Capacità lorda: 272 lt • Capacità netta: 254 lt  
Termostato: Elettronico • Sbrinamento: Automatico  
Termometro: Elettronico  
Refrigerazione: Statica con agitatore  
Luce LED con interruttore • Serratura con chiave  
4 piedini regolabili • Colore esterno: Nero  
6 griglie (375 x 345 mm)

W x D x H: 1335 x 500 x 900 mm  
Display area: 0,835 smt  
Climatic class: 4 • Gas: R600a  
Energy consumption (24h): 1,50 kW  
Gross capacity: 272 lt • Net capacity: 254 lt  
Thermostat: Electronic • Defrosting: Automatic  
Thermometer: Electronic  
Refrigeration: Static with fan  
LED light with switch • Key lock  
4 Adjustable feet • Body colour: Black  
6 shelves (375 x 345 mm)



336 x 33 cl



150 x 66 cl



62 x 1,5 lt



Automatic  
Defrost



ECO  
Friendly



Made by  
U5  
Partners



GAS "HC"  
R600a



BEVERAGE

ESPOSITORI SOTTOBANCO • UNDER COUNTER COOLERS

# FV 200 S

+2°/+10° C



Serratura con chiave  
Key lock

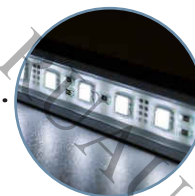

Luce interna LED  
Internal LED light

L x P x H: 400 x 574 x 1848 mm  
 Area visibile: 0,40 mq • Classe climatica: 4  
 Capacità lorda: 210 lt • Capacità netta: 175 lt  
 Termostato: Meccanico • Sbrinamento: Manuale  
 Termometro: Meccanico • Gas: R600a  
 Refrigerazione: Statica con agitatore  
 Luce LED con interruttore • Serratura con chiave  
 2 piedini regolabili + 4 rullini  
 Colore esterno: Grigio silver  
 4 griglie (293 x 350 mm)

W x D x H: 400 x 574 x 1848 mm  
 Display area: 0,40 smt • Climatic class: 4  
 Gross capacity: 210 lt • Net capacity: 175 lt  
 Thermostat: Mechanic • Defrosting: Manual  
 Thermometer: Mechanic • Gas: R600a  
 Refrigeration: Static with fan  
 LED light with switch • Key lock  
 2 adjustable feet + 4 rollers  
 Body colour: Silver Grey  
 4 shelves (293 x 350 mm)



336 x 33 cl



150 x 66 cl



62 x 1,5 lt



## A RICHIESTA • OPTIONAL

Grafica su 2 lati e/o vetro frontale • Inversione porta • Termostato elettronico  
 Graphic on 2 sides and/or frontal glass • Inversion of the door • Electronic thermostat

# FV 200 S BLACK

+2°/+10° C



BEVERAGE  
VETRINE VERTICALI • UPRIGHT DISPLAY COOLERS



Serratura con chiave  
Key lock

Luce interna LED  
Internal LED light

L x P x H: 400 x 574 x 1848 mm  
Area visibile: 0,40 mq • Classe climatica: 4  
Capacità lorda: 210 lt • Capacità netta: 175 lt  
Termostato: Meccanico • Sbrinamento: Manuale  
Termometro: Meccanico • Gas: R600a  
Refrigerazione: Statica con agitatore  
Luce LED con interruttore • Serratura con chiave  
2 piedini regolabili + 4 rullini  
Colore esterno: Nero  
4 griglie (293 x 350 mm)

W x D x H: 400 x 574 x 1848 mm  
Display area: 0,40 smt • Climatic class: 4  
Gross capacity: 210 lt • Net capacity: 175 lt  
Thermostat: Mechanic • Defrosting: Manual  
Thermometer: Mechanic • Gas: R600a  
Refrigeration: Static with fan  
LED light with switch • Key lock  
2 adjustable feet + 4 rollers  
Body colour: Black  
4 shelves (293 x 350 mm)



336 x 33 cl



150 x 66 cl



62 x 1,5 lt



## A RICHIESTA • OPTIONAL

Grafica su 2 lati e/o vetro frontale • Inversione porta • Termostato elettronico  
Graphic on 2 sides and/or frontal glass • Inversion of the door • Electronic thermostat

# FV 300 S

+2°/+10° C



Serratura con chiave  
Key lock

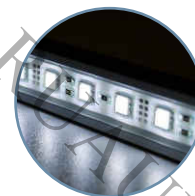

Luce interna LED  
Internal LED light

L x P x H 442 x 699 x 1848 mm  
 Area visibile: 0,492 mq • Classe climatica: 4  
 Consumo energetico (24h): 1,98 kW  
 Capacità lorda: 313 lt • Capacità netta: 235 lt  
 Termostato: Meccanico • Sbrinamento: Manuale  
 Termometro: Meccanico • Gas: R600a  
 Refrigerazione: Statica con agitatore  
 Luce LED con interruttore • Serratura con chiave  
 2 piedini regolabili + 4 rullini  
 Colore esterno: Grigio silver  
 4 griglie (345 x 435 mm)

W x D x H: 442 x 699 x 1848 mm  
 Display area: 0,492 mq/0,49 smt • Climatic class: 4  
 Energy consumption (24h): 1,98 kW  
 Gross capacity: 313 lt • Net capacity: 235 lt  
 Thermostat: Mechanic • Defrosting: Manual  
 Thermometer: Mechanic • Gas: R600a  
 Refrigeration: Static with fan  
 LED light with switch • Key lock  
 2 adjustable feet + 4 rollers  
 Colore esterno: Silver Grey  
 4 shelves (345 x 435 mm)



320 x 33 cl



80 x 66 cl



36 x 1,5 lt



## A RICHIESTA • OPTIONAL

Grafica su 2 lati e/o vetro frontale • Inversione porta • Termostato elettronico  
 Graphic on 2 sides and/or frontal glass • Inversion of the door • Electronic thermostat

# FV 300 S BLACK

+2°/+10° C



BEVERAGE  
VETRINE VERTICALI • UPRIGHT DISPLAY COOLERS



Serratura con chiave  
Key lock



Luce interna LED  
Internal LED light

L x P x H 442 x 699 x 1848 mm  
Area visibile: 0,492 mq • Classe climatica: 4  
Consumo energetico (24h): 1,98 kW  
Capacità lorda: 313 lt • Capacità netta: 235 lt  
Termostato: Meccanico • Sbrinamento: Manuale  
Termometro: Meccanico • Gas: R600a  
Refrigerazione: Statica con agitatore  
Luce LED con interruttore • Serratura con chiave  
2 piedini regolabili + 4 rullini  
Colore esterno: Nero  
4 griglie (345 x 435 mm)

W x D x H: 442 x 699 x 1848 mm  
Display area: 0,492 mq/0,49 smt • Climatic class: 4  
Energy consumption (24h): 1,98 kW  
Gross capacity: 313 lt • Net capacity: 235 lt  
Thermostat: Mechanic • Defrosting: Manual  
Thermometer: Mechanic • Gas: R600a  
Refrigeration: Static with fan  
LED light with switch • Key lock  
2 adjustable feet + 4 rollers  
Colore esterno: Black  
4 shelves (345 x 435 mm)



320 x 33 cl



80 x 66 cl



36 x 1,5 lt



## A RICHIESTA • OPTIONAL

Grafica su 2 lati e/o vetro frontale • Inversione porta • Termostato elettronico  
Graphic on 2 sides and/or frontal glass • Inversion of the door • Electronic thermostat

# FV 300 S RETRÒ

+2°/+10° C



Luce interna LED  
Internal LED light

L x P x H: 442 x 730 x 1960 mm  
Area visibile: 0,402 mq • Classe climatica: 4  
Capacità lorda: 313 lt • Capacità netta: 235 lt  
Termostato: Meccanico • Sbrinamento: Manuale  
Termometro: Meccanico • Gas: R600a  
Refrigerazione: Statica con agitatore  
Luce LED con interruttore  
2 piedini regolabili + 4 rullini  
Colore esterno: Grigio silver  
4 griglie (345 x 435 mm)

W x D x H: 442 x 730 x 1960 mm  
Display area: 0,402 smt • Climatic class: 4  
Gross capacity: 313 lt • Net capacity: 235 lt  
Thermostat: Mechanic • Defrosting: Manual  
Thermometer: Mechanic • Gas: R600a  
Refrigeration: Static with fan  
LED light with switch  
2 adjustable feet + 4 rollers  
Body colour: Silver Grey  
4 shelves (345 x 435 mm)



320 x 33 cl



80 x 66 cl



36 x 1,5 lt



## A RICHIESTA • OPTIONAL

Grafica su 2 lati, opalina luminosa e porta  
Graphic on 2 sides, backlight canopy and door

# FV 390.1 CL

## +2°/+12° C



Serratura con chiave  
Key lock



Luce interna LED  
Internal LED light

L x P x H: 590 x 620 x 2069 mm  
 Area visibile: 0,730 mq • Classe climatica: 4  
 Watt: 217 • Consumo energetico (24h): 1,94 kW  
 Capacità lorda: 355 lt • Capacità netta: 341 lt  
 Termostato: Meccanico • Sbrinamento: Manuale  
 Termometro: Meccanico • Gas: R600a  
 Refrigerazione: Statica con agitatore  
 Luce LED con interruttore  
 Serratura con chiave • 2 piedini regolabili + 2 rullini  
 Colore esterno: Grigio silver  
 5 griglie (505 x 350mm)

W x D x H: 590 x 620 x 2069 mm  
 Display area: 0,730 sm<sup>2</sup> • Climatic class: 4  
 Watt: 217 • Energy consumption (24h): 1,94 kW  
 Gross capacity: 355 lt • Net capacity: 341 lt  
 Thermostat: Mechanic • Defrosting: Manual  
 Thermometer: Mechanic • Gas: R600a  
 Refrigeration: Static with fan  
 LED light with switch  
 Key lock • 2 adjustable feet +2 rollers  
 Body colour: Silver Grey  
 5 shelves (505 x 350 mm)



402 x 33 cl



168 x 66 cl



90 x 1,5 lt



### A RICHIESTA • OPTIONAL

Grafica su 2 lati, vetro frontale e cassonetto luminoso  
 Graphic on 2 sides, frontal glass and back light canopy

# FV 390.1 CL BLACK

+2°/+12° C



Serratura con chiave  
Key lock

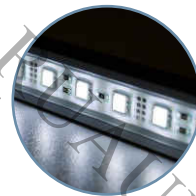

Luce interna LED  
Internal LED light



L x P x H: 590 x 620 x 2069 mm  
 Area visibile: 0,730 mq • Classe climatica: 4  
 Watt: 217 • Consumo energetico (24h): 1,94 kW  
 Capacità lorda: 355 lt • Capacità netta: 341 lt  
 Termostato: Meccanico • Sbrinamento: Manuale  
 Termometro: Meccanico • Gas: R600a  
 Refrigerazione: Statica con agitatore  
 Luce LED con interruttore  
 Serratura con chiave • 2 piedini regolabili + 2 rullini  
 Colore esterno: Nero  
 5 griglie (505 x 350mm)

W x D x H: 590 x 620 x 2069 mm  
 Display area: 0,730 smt • Climatic class: 4  
 Watt: 217 • Energy consumption (24h): 1,94kW  
 Gross capacity: 355 lt • Net capacity: 341 lt  
 Thermostat: Mechanic • Defrosting: Manual  
 Thermometer: Mechanic • Gas: R600a  
 Refrigeration: Static with fan  
 LED light with switch  
 Key lock • 2 adjustable feet +2 rollers  
 Body colour: Black  
 5 shelves (505 x 350 mm)



## A RICHIESTA • OPTIONAL

Grafica su 2 lati, vetro frontale e cassonetto luminoso  
 Graphic on 2 sides, frontal glass and back light canopy

# KRYO 14 P

+2°/+10° C



Serratura con chiave  
Key lock



Termostato elettronico  
Electronic thermostat



Luce interna LED  
Internal LED light

L x P x H: 610 x 605 x 840 mm  
Area visibile: 0,296 mq • Classe climatica: 4  
Capacità lorda: 120 lt • Capacità netta: 108 lt  
Termostato: Elettronico • Sbrinamento: Manuale  
Termometro: Digitale • Gas: R600a  
Refrigerazione: Statica con agitatore  
Luce LED con interruttore • Serratura con chiave  
2 piedini regolabili + 2 rullini  
Colore esterno: Grigio silver  
2 griglie (455 x 397 mm)

W x D x H: 610 x 605 x 840 mm  
Display area: 0,296 smt • Climatic class: 4  
Gross capacity: 120 lt • Net capacity: 108 lt  
Thermostat: Electronic • Defrosting: Manual  
Thermometer: Digital • Gas: R600a  
Refrigeration: Static with fan  
LED light with switch • Key lock  
2 adjustable feet + 2 rollers  
Body colour: Silver Grey  
2 shelves (455 x 397 mm)



84 x 33 cl



36 x 66 cl



## A RICHIESTA • OPTIONAL

Grafica su 2 lati e/o vetro frontale • Inversione porta  
Graphic on 2 sides and/or frontal glass • Inversion of the door

# KRYO 42 EVO

+2°/+10° C



Serratura con chiave  
Key lock

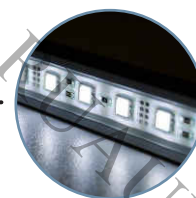

Luce interna LED  
Internal LED light

L x P x H: 610 x 605 x 1843 mm  
 Area visibile: 0,746 mq • Classe climatica: 4  
 Watt: 223 • Consumo energetico (24h): 2,52 kW  
 Capacità lorda: 376 lt • Capacità netta: 292 lt  
 Termostato: Meccanico • Sbrinamento: Manuale  
 Termometro: Meccanico • Gas: R600a  
 Refrigerazione: Statica con agitatore  
 Luce LED con interruttore • Serratura con chiave  
 2 piedini regolabili + 2 rullini  
 Colore esterno: Grigio silver  
 4 griglie (502 x 397 mm)

W x D x H: 610 x 605 x 1843 mm  
 Display area: 0,746 smt • Climatic class: 4  
 Watt: 223 • Energy consumption (24h): 2,52 kW  
 Gross capacity: 376 lt • Net capacity: 292 lt  
 Thermostat: Mechanic • Defrosting: Manual  
 Thermometer: Mechanic • Gas: R600a  
 Refrigeration: Static with fan  
 LED light with switch • Key lock  
 2 adjustable feet + 2 rollers  
 Body colour: Silver Grey  
 4 shelves (502 x 397 mm)



434 x 33 cl



132 x 66 cl



80 x 1,5 lt



## A RICHIESTA • OPTIONAL

Grafica su 2 lati, vetro frontale • Kit LED verticale • Inversione porta  
 Graphic on 2 sides, frontal glass • Vertical LED kit • Inversion of the door

# KRYO 42 EVO BLACK

+2°/+10° C



BEVERAGE  
VETRINE VERTICALI • UPRIGHT DISPLAY COOLERS



Serratura con chiave  
Key lock

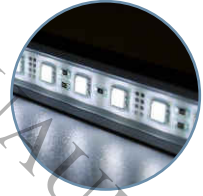

Luce interna LED  
Internal LED light

L x P x H: 610 x 605 x 1843 mm  
Area visibile: 0,746 mq • Classe climatica: 4  
Watt: 223 • Consumo energetico (24h): 2,52 kW  
Capacità lorda: 376 lt • Capacità netta: 292 lt  
Termostato: Meccanico • Sbrinamento: Manuale  
Termometro: Meccanico • Gas: R600a  
Refrigerazione: Statica con agitatore  
Luce LED con interruttore • Serratura con chiave  
2 piedini regolabili + 2 rullini  
Colore esterno: Nero  
4 griglie (502 x 397 mm)

W x D x H: 610 x 605 x 1843 mm  
Display area: 0,746 smt • Climatic class: 4  
Watt: 223 • Energy consumption (24h): 2,52 kW  
Gross capacity: 376 lt • Net capacity: 292 lt  
Thermostat: Mechanic • Defrosting: Manual  
Thermometer: Mechanic • Gas: R600a  
Refrigeration: Static with fan  
LED light with switch • Key lock  
2 adjustable feet + 2 rollers  
Body colour: Black  
4 shelves (502 x 397 mm)



434 x 33 cl



132 x 66 cl



80 x 1,5 lt



## A RICHIESTA • OPTIONAL

Grafica su 2 lati, vetro frontale • Kit LED verticale • Inversione porta  
Graphic on 2 sides, frontal glass • Vertical LED kit • Inversion of the door

# KRYO 42 EVO CL

+2°/+10° C



Serratura con chiave  
Key lock



Luce interna LED  
Internal LED light

L x P x H: 610 x 605 x 2000 mm  
 Area visibile: 0,746 mq • Classe climatica: 4  
 Watt: 228 • Consumo energetico (24h): 2,65 kW  
 Capacità lorda: 376 lt • Capacità netta: 292 lt  
 Termostato: Meccanico • Sbrinamento: Manuale  
 Termometro: Meccanico • Gas: R600a  
 Refrigerazione: Statica con agitatore  
 Luce LED con interruttore • Serratura con chiave  
 2 piedini regolabili + 2 rullini  
 Colore esterno: Grigio silver  
 4 griglie (502 x 397 mm)

W x D x H: 610 x 605 x 2000 mm  
 Display area: 0,746 smt • Climatic class: 4  
 Watt: 228 • Energy consumption (24h): 2,65 kW  
 Gross capacity: 376 lt • Net capacity: 292 lt  
 Thermostat: Mechanic • Defrosting: Manual  
 Thermometer: Mechanic • Gas: R600a  
 Refrigeration: Static with fan  
 LED light with switch • Key lock  
 2 adjustable feet + 2 rollers  
 Body colour: Silver grey  
 4 shelves (502 x 397 mm)



434 x 33 cl



132 x 66 cl



80 x 1,5 lt



## A RICHIESTA • OPTIONAL

Grafica su 2 lati, vetro frontale e cassetto luminoso • Kit LED verticale • Inversione porta  
 Graphic on 2 sides, frontal glass and backlight canopy • Vertical LED kit • Inversion of the door

# KRYO 42 EVO CL BLACK

+2°/+10° C



BEVERAGE  
VETRINE VERTICALI • UPRIGHT DISPLAY COOLERS

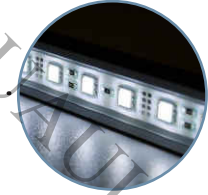

Luce interna LED  
Internal LED light



Serratura con chiave  
Key lock

L x P x H: 610 x 605 x 2000 mm  
Area visibile: 0,746 mq • Classe climatica: 4  
Watt: 228 • Consumo energetico (24h): 2,65 kW  
Capacità lorda: 376 lt • Capacità netta: 292 lt  
Termostato: Meccanico • Sbrinamento: Manuale  
Termometro: Meccanico • Gas: R600a  
Refrigerazione: Statica con agitatore  
Luce LED con interruttore • Serratura con chiave  
2 piedini regolabili + 2 rullini  
Colore esterno: Nero  
4 griglie (502 x 397 mm)

W x D x H: 610 x 605 x 2000 mm  
Display area: 0,746 smt • Climatic class: 4  
Watt: 228 • Energy consumption (24h): 2,65 kW  
Gross capacity: 376 lt • Net capacity: 292 lt  
Thermostat: Mechanic • Defrosting: Manual  
Thermometer: Mechanic • Gas: R600a  
Refrigeration: Static with fan  
LED light with switch • Key lock  
2 adjustable feet + 2 rollers  
Body colour: Black  
4 shelves (502 x 397 mm)



434 x 33 cl



132 x 66 cl



80 x 1,5 lt



## A RICHIESTA • OPTIONAL

Grafica su 2 lati, vetro frontale e cassonetto luminoso • Kit LED verticale • Inversione porta  
Graphic on 2 sides, frontal glass and backlight canopy • Vertical LED kit • Inversion of the door

# KRYO 42 PV

+2°/+10° C



Serratura con chiave  
Key lock



Termostato elettronico  
Electronic thermostat



Luce interna LED  
Internal LED light



Tel (France) +33 (0)6 60 52 14 38

L x P x H: 602 x 673 x 1886 mm  
Area visibile: 0,766 mq • Classe climatica: 4  
Watt: 170 • Consumo energetico (24h): 2,7 kW  
Capacità lorda: 375 lt • Capacità netta: 286 lt  
Termostato: Elettronico • Sbrinamento: Manuale  
Termometro: Elettronico • Gas: R600a  
Refrigerazione: Ventilata  
Luce LED • Serratura con chiave  
2 piedini regolabili + 2 rullini  
Colore esterno: Grigio silver  
4 griglie (495 x 401 mm)

W x D x H: 602 x 673 x 1886 mm  
Display area: 0,766 smt • Climatic class: 4  
Watt: 170 • Energy consumption (24h): 2,7 kW  
Gross capacity: 375 lt • Net capacity: 286 lt  
Thermostat: Electronic • Defrosting: Manual  
Thermometer: Electronic • Gas: R600a  
Refrigeration: Ventilated  
LED light • Key lock  
2 adjustable feet + 2 rollers  
Body colour: Silver grey  
4 shelves (495 x 401 mm)



420 x 33 cl



120 x 66 cl



60 x 1,5 lt



## A RICHIESTA • OPTIONAL

Grafica su 2 lati e/o vetro frontale • Inversione porta  
Graphic on 2 sides and/or frontal glass • Inversion of the door

# KRYO 70 P

+2°/+10° C



Serratura con chiave  
Key lock



Termostato elettronico  
Electronic thermostat



Luce interna LED  
Internal LED light



L x P x H: 778 x 783 x 1883 mm  
 Area visibile: 1,030 mq • Classe climatica: 4  
 Capacità lorda: 610 lt • Capacità netta: 510 lt  
 Termostato: Elettronico • Sbrinamento: Manuale  
 Termometro: Elettronico • Gas: R600a  
 Refrigerazione: Statica con agitatore  
 Luce LED • Serratura con chiave  
 2 piedini regolabili + 4 rullini  
 Colore esterno: Grigio silver  
 4 griglie (637 x 546 mm)

W x D x H: 778 x 783 x 1883 mm  
 Display area: 1,030 smt • Climatic class: 4  
 Gross capacity: 610 lt • Net capacity: 510 lt  
 Thermostat: Electronic • Defrosting: Manual  
 Thermometer: Electronic • Gas: R600a  
 Refrigeration: Static with fan  
 LED light • Key lock  
 2 adjustable feet + 4 rollers  
 Body colour: Silver grey  
 4 shelves (637 x 546 mm)



720 x 33 cl



225 x 66 cl



140 x 1,5 lt



## A RICHIESTA • OPTIONAL

Grafica su 2 lati e/o vetro frontale • Inversione porta  
 Graphic on 2 sides and/or frontal glass • Inversion of the door

# FV 110 S

+2°/+10° C



Serratura con chiave  
Key lock



Interruttori luce  
Light switch



Luce interna LED  
Internal LED light



Termostato elettronico  
Electronic thermostat

L x P x H: 1130 x 705 x 2025 mm  
Area visibile: 1,150 mq • Classe climatica: 4  
Watt: 750 • Consumo energetico (24h): 6,5 kW  
Capacità lorda: 1000 lt • Capacità netta: 722 lt  
Termostato: Elettronico • Sbrinamento: Automatico  
Termometro: Elettronico • Gas: R290a  
Refrigerazione: Ventilata  
2 Luci LED interne • Serratura con chiave  
4 ruote pivotanti con freno  
Colore esterno: Bianco e nero  
8 griglie (502 x 465 mm)

W x D x H: 1130 x 705 x 2025 mm  
Display area: 1,150 smt • Climatic class: 4  
Watt: 750 • Energy consumption (24h): 6,5 kW  
Gross capacity: 1000 lt • Net capacity: 722 lt  
Thermostat: Electronic • Defrosting: Automatic  
Thermometer: Electronic • Gas: R290a  
Refrigeration: Ventilated  
2 internal LED light • Key lock  
4 pivoting wheels with brake  
Body colour: White and black  
8 shelves (502 x 465 mm)



576 x 33 cl



360 x 66 cl



150 x 1,5 lt



Automatic Defrost



Ventilato  
Ventilated



ECO  
Friendly



GAS "HC"  
R290



## A RICHIESTA • OPTIONAL

Grafica su 2 lati e/o vetro frontale • Cassonetto luminoso  
Graphic on 2 sides and/or frontal glass • Backlight canopy

# CW 40

+5°/+20° C

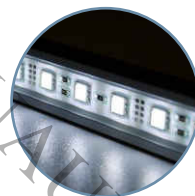

Luce interna LED  
Internal LED light

L x P x H: 485 x 600 x 820 mm  
Area visibile: 0,273 mq • Classe climatica: 4  
Watt: 110 • Consumo energetico (24h): 0,35 kW  
Capacità lorda: 122 lt • Capacità netta: 118 lt  
Termostato: Elettronico • Sbrinamento: Manuale  
Termometro: Elettronico • Gas: R600a  
Luce LED • 4 piedini regolabili  
Colore esterno: Nero  
3 griglie in legno (395 x 435 mm)

W x D x H: 485 x 600 x 820 mm  
Display area: 0,273 smt • Climatic class: 4  
Watt: 110 • Energy consumption (24h): 0,35 kW  
Gross capacity: 122 lt • Net capacity: 118 lt  
Thermostat: Electronic • Defrosting: Manual  
Thermometer: Electronic • Gas: R600a  
LED light • 4 adjustable feet  
Body colour: Black  
3 wood shelves (395 x 435 mm)



49



**A RICHIESTA • OPTIONAL**  
Grafica su 2 lati - vetro frontale  
Graphic on 2 sides - front glass

# CW 85

+5°/+20° C

Votre distributeur : RUVAULT Design

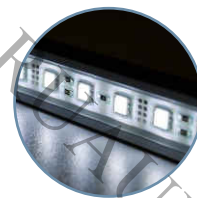

Luce interna LED  
Internal LED light

Tél (France)

L x P x H: 480 x 595 x 1285 mm  
Area visibile: 0,369 mq • Classe climatica: 4  
Watt: 150 • Consumo energetico (24h): 0,393 kW  
Capacità lorda: 204 lt • Capacità netta: 200 lt  
Termostato: Elettronico • Sbrinamento: Manuale  
Termometro: Elettronico • Gas: R600a  
Refrigerazione: Statica con agitatore  
Luce LED • 4 piedini regolabili  
Colore esterno: Nero  
10 griglie in legno (395 x 435 mm)

W x D x H: 480 x 595 x 1285 mm  
Display area: 0,369 smt • Climatic class: 4  
Watt: 150 • Energy consumption (24h): 0,393 kW  
Gross capacity: 204 lt • Net capacity: 200 lt  
Thermostat: Electronic • Defrosting: Manual  
Thermometer: Electronic • Gas: R600a  
Refrigeration: Static with fan  
LED light • 4 adjustable feet  
Body colour: Black  
10 wood shelves (395 x 435 mm)



85



**A RICHIESTA • OPTIONAL**  
Grafica su 2 lati - vetro frontale  
Graphic on 2 sides - front glass

# CW 400

+5°/+15° C



Serratura con chiave  
Key lock

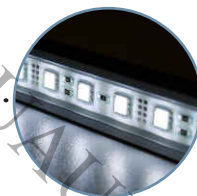

Luce interna LED  
Internal LED light

L x P x H: 610 x 605 x 1843 mm  
Area visibile: 0,746 mq • Classe climatica: 4  
Watt: 225 • Consumo energetico (24h): 2,88 kW  
Capacità lorda: 376 lt • Capacità netta: 292 lt  
Termostato: Meccanico • Sbrinamento: Manuale  
Termometro: Meccanico • Gas: R600a  
Refrigerazione: Statica con agitatore  
Luce LED con interruttore • Serratura con chiave  
2 piedini regolabili + 2 rullini  
Colore esterno: Nero  
4 griglie (502 x 397 mm)

W x D x H: 610 x 605 x 1843 mm  
Display area: 0,746 smt • Climatic class: 4  
Watt: 225 • Energy consumption (24h): 2,88 kW  
Gross capacity: 376 lt • Net capacity: 292 lt  
Thermostat: Mechanic • Defrosting: Manual  
Thermometer: Mechanic • Gas: R600a  
Refrigeration: Static with fan  
LED light with switch • Key lock  
2 adjustable feet + 2 rollers  
Body colour: Black  
4 shelves (502 x 397 mm)



84



55



90



**A RICHIESTA • OPTIONAL**  
Grafica su 2 lati - vetro frontale  
Graphic on 2 sides - front glass

# CW 400 MT

+5°/+15° C



Serratura con chiave  
Key lock

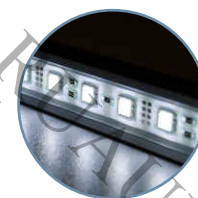

Luce interna LED  
Internal LED light

L x P x H: 610 x 605 x 1843 mm  
 Area visibile: 0,746 mq • Classe climatica: 4  
 Watt: 174 • Consumo energetico (24h): 2,55 kW  
 Capacità lorda: 376 lt • Capacità netta: 292 lt  
 Termostato: Elettronico • Sbrinamento: Manuale  
 Termometro: Elettronico • Gas: R600a  
 Refrigerazione: Statica  
 Luce LED interna • Serratura con chiave  
 2 piedini regolabili + 2 rullini  
 Colore esterno: Nero  
 4 griglie (502 x 397 mm)

W x D x H: 610 x 605 x 1843 mm  
 Display area: 0,746 smt • Climatic class: 4  
 Watt: 174 • Energy consumption (24h): 2,55 kW  
 Gross capacity: 376 lt • Net capacity: 292 lt  
 Thermostat: Electronic • Defrosting: Manual  
 Thermometer: Electronic • Gas: R600a  
 Refrigeration: Static  
 Internal LED light • Key lock  
 2 adjustable feet + 2 rollers  
 Body colour: Black  
 4 shelves (502 x 397 mm)



84



55



90



**A RICHIESTA • OPTIONAL**  
 Grafica su 2 lati - vetro frontale  
 Graphic on 2 sides - front glass

# CW 400 MT INOX

+5°/+15° C



BEVERAGE  
VETRINE VERTICALI • UPRIGHT DISPLAY COOLERS



Serratura con chiave  
Key lock

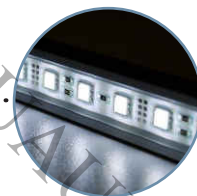

Luce interna LED  
Internal LED light

L x P x H: 610 x 605 x 1843 mm  
Area visibile: 0,746 mq • Classe climatica: 4  
Watt: 174 • Consumo energetico (24h): 2,55 kW  
Capacità lorda: 376 lt • Capacità netta: 292 lt  
Termostato: Elettronico • Sbrinamento: Manuale  
Termometro: Elettronico • Gas: R600a  
Refrigerazione: Statica  
Luce LED interna • Serratura con chiave  
2 piedini regolabili + 2 rullini  
Colore esterno: Acciaio inox  
4 griglie (502 x 397 mm)

W x D x H: 610 x 605 x 1843 mm  
Display area: 0,746 smt • Climatic class: 4  
Watt: 174 • Energy consumption (24h): 2,55 kW  
Gross capacity: 376 lt • Net capacity: 292 lt  
Thermostat: Electronic • Defrosting: Manual  
Thermometer: Electronic • Gas: R600a  
Refrigeration: Static  
Internal LED light • Key lock  
2 adjustable feet + 2 rollers  
Body colour: Stainless steel  
4 shelves (502 x 397 mm)



84



55



90



**A RICHIESTA • OPTIONAL**  
Grafica su 2 lati - vetro frontale  
Graphic on 2 sides - front glass

# WINE CLASS

+5°/+15° C

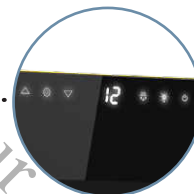

• Touch screen



• Luce interna LED  
Internal LED light



• Serratura con chiave  
Key lock

L x P x H: 610 x 605 x 1843 mm  
 Area visibile: 1,380 mq • Classe climatica: 4  
 Watt: 245 • Consumo energetico (24h): 3,25 kW  
 Capacità lorda: 376 lt • Capacità netta: 292 lt  
 Refrigerazione: Statica con agitatore  
 Termostato: Elettronico  
 Sbrinamento: Manuale • Termometro: Elettronico  
 Gas: R600a • Luce LED interna  
 Serratura con chiave • 2 piedini regolabili + 2 rullini  
 Colore esterno: Acciaio inox  
 4 griglie (502 x 397 mm)

W x D x H: 610 x 605 x 1843 mm  
 Display area: 1,380 smt • Climatic class: 4  
 Watt: 245 • Energy consumption (24h): 3,25 kW  
 Gross capacity: 376 lt • Net capacity: 292 lt  
 Refrigeration: Static with fan  
 Ventilated refrigeration • Thermostat: Electronic  
 Defrosting: Manual • Thermometer: Electronic  
 Gas: R600a • Internal LED light  
 Key lock • 2 adjustable feet + 2 rollers  
 Body colour: Stainless steel  
 4 shelves (502 x 397 mm)



84



55



90



**A RICHIESTA • OPTIONAL**

Grafica su 2 lati - vetro frontale • Luci LED Rgb  
 Graphic on 2 sides - front glass • Rgb LED lights

*Duerighedesign*

# WINE CLASS S

+5°/+15° C

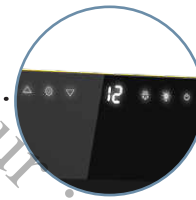

Touch screen



Luce interna LED  
Internal LED light



Serratura con chiave  
Key lock

L x P x H: 610 x 605 x 1843 mm  
 Area visibile: 1,380 mq • Classe climatica: 4  
 Watt: 245 • Consumo energetico (24h): 3,25 kW  
 Capacità lorda: 376 lt • Capacità netta: 292 lt  
 Refrigerazione: Statica con agitatore  
 Termostato: Elettronico  
 Sbrinamento: Manuale • Termometro: Elettronico  
 Gas: R600a • Luce LED interna  
 Serratura con chiave • 2 piedini regolabili + 2 rullini  
 Colore esterno: Acciaio inox  
 7 ripiani in plexiglass

W x D x H: 610 x 605 x 1843 mm  
 Display area: 1,380 smt • Climatic class: 4  
 Watt: 245 • Energy consumption (24h): 3,25 kW  
 Gross capacity: 376 lt • Net capacity: 292 lt  
 Refrigeration: Static with fan  
 Ventilated refrigeration • Thermostat: Electronic  
 Defrosting: Manual • Thermometer: Electronic  
 Gas: R600a • Internal LED light  
 Key lock • 2 adjustable feet + 2 rollers  
 Body colour: Stainless steel  
 7 transparent shelves



35

35

35

Possibilità di posizionare le bottiglie vino con tappo in giù o con tappo in su  
 Possibility to place wine bottles with caps down or with caps up.



## A RICHIESTA • OPTIONAL

Grafica su 2 lati - vetro frontale • Luci LED Rgb  
 Graphic on 2 sides - front glass • Rgb LED lights

*Duerighedesign*

# CW 400 L

+5°/+15° C



Serratura con chiave  
Key lock



Luce interna LED  
Internal LED light

L x P x H: 640 x 613 x 1885 mm  
 Area visibile: 0,746 mq • Classe climatica: 4  
 Watt: 225 • Consumo energetico (24h): 2,88 kW  
 Capacità lorda: 376 lt • Capacità netta: 292 lt  
 Termostato: Meccanico • Sbrinamento: Manuale  
 Termometro: Meccanico • Gas: R600a  
 Refrigerazione: Statica con agitatore  
 Luce LED con interruttore • Serratura con chiave  
 2 piedini regolabili + 2 rullini  
 Colore esterno: Legno  
 4 griglie (502 x 397 mm)

W x D x H: 640 x 613 x 1885 mm  
 Display area: 0,746 smt • Climatic class: 4  
 Watt: 225 • Energy consumption (24h): 2,88 kW  
 Gross capacity: 376 lt • Net capacity: 292 lt  
 Thermostat: Mechanic • Defrosting: Manual  
 Thermometer: Mechanic • Gas: R600a  
 Refrigeration: Static with fan  
 LED light with switch • Key lock  
 2 adjustable feet + 2 rollers  
 Body colour: Wood  
 4 shelves (502 x 397 mm)



84



55



90



## A RICHIESTA • OPTIONAL

Grafica su vetro frontale  
Graphic on front glass

# CW 800 L

+5°/+15° C

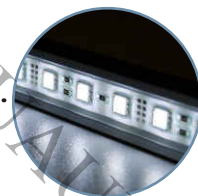

Luce interna LED  
Internal LED light

L x P x H: 1350 x 613 x 1885 mm  
Area visibile: 1,491 mq • Classe climatica: 4  
Watt: 450 • Consumo energetico (24h): 5,76 kW  
Capacità lorda: 752 lt • Capacità netta: 584 lt  
Termostato: Meccanico • Sbrinamento: Manuale  
Termometro: Meccanico • Gas: R600a  
Refrigerazione: Statica con agitatore  
Luce LED con interruttore  
4 piedini regolabili + 4 rullini  
Colore esterno: Legno  
8 griglie (502 x 397 mm)

W x D x H: 1350 x 613 x 1885 mm  
Display area: 1,491 smt • Climatic class: 4  
Watt: 450 • Energy consumption (24h): 5,76 kW  
Gross capacity: 752 lt • Net capacity: 584 lt  
Thermostat: Mechanic • Defrosting: Manual  
Thermometer: Mechanic • Gas: R600a  
Refrigeration: Static with fan  
LED light with switch  
4 adjustable feet + 4 rollers  
Body colour: Wood  
8 shelves (502 x 397 mm)



168



110



180



#### A RICHIESTA • OPTIONAL

Grafica su vetro frontale  
Graphic on front glass

# ICE CREAM

[contact@groupe-ruault.com](mailto:contact@groupe-ruault.com)

Tél (France) : +33

Votre distributeur : RUAULT Design



# CUBE

-18°/-23° C



Votre distributeur : RU AULT Design



Luce interna LED  
Internal LED light



Serratura con chiave  
Key lock



L x P x H: 580 x 537 x 533 mm  
Area visibile: 0,19 mq • Classe climatica: 4  
Watt: 89 • Consumo energetico (24h): 1,40 kW  
Capacità lorda: 52 lt • Capacità netta: 48 lt  
Termostato: Meccanico • Sbrinamento: Manuale  
Termometro: Meccanico • Refrigerazione: Statica  
Gas: R600a • Luce LED con interruttore  
Serratura con chiave • 4 piedini regolabili  
Colore esterno: Grigio silver  
2 griglie (433 x 204 mm)

W x D x H: 580 x 537 x 533 mm  
Display area: 0,19 smt • Climatic class: 4  
Watt: 89 • Energy consumption (24h): 1,40 kW  
Gross capacity: 52 lt • Net capacity: 48 lt  
Thermostat: Mechanic • Defrosting: Manual  
Thermometer: Mechanic • Refrigeration: Static  
Gas: R600a • LED light with switch  
Key lock • 4 adjustable feet  
Body colour: Silver Grey  
2 shelves (433 x 204 mm)



## A RICHIESTA • OPTIONAL

Grafica su mobile e/o vetro frontale  
Graphic on body and/or front glass

contattaci@groupe-ruault.com

**IQ**  
-18°/-23° C



Termostato elettronico  
Electronic thermostat



Serratura con chiave  
Key lock



L x P x H: 500 x 483 x 1000 mm  
Area visibile: 0,255 mq • Classe climatica: 7  
Watt: 220 • Consumo energetico (24h): 1,47 kW  
Capacità lorda: 79 lt • Capacità netta: 61 lt  
Termostato: Elettronico • Sbrinamento: Manuale  
Termometro: Elettronico • Refrigerazione: Statica  
Gas: R290 • Luce LED con interruttore  
Serratura con chiave • 4 piedini regolabili  
Colore esterno: Grigio silver  
2 griglie (360 x 280 mm)

W x D x H: 500 x 483 x 1000 mm  
Display area: 0,255 smt • Climatic class: 7  
Watt: 220 • Energy consumption (24h): 1,47 kW  
Gross capacity: 79 lt • Net capacity: 61 lt  
Thermostat: Electronic • Defrosting: Manual  
Thermometer: Electronic • Refrigeration: Static  
Gas: R290 • LED light with switch  
Key lock • 4 adjustable feet  
Body colour: Silver Grey  
2 shelves (360 x 280 mm)



**A RICHIESTA • OPTIONAL**

Grafica su mobile e/o vetro frontale  
Graphic on body and/or front glass

*Duerighedesign*

# IQ GLAMOUR

-18°/-23° C



Termostato elettronico  
Electronic thermostat



Serratura con chiave  
Key lock



L x P x H: 500 x 483 x 1000 mm  
Area visibile: 0,692 mq • Classe climatica: 7  
Watt: 270 • Consumo energetico (24h): 1,81 kW  
Capacità lorda: 79 lt • Capacità netta: 57 lt  
Termostato: Elettronico • Sbrinamento: Manuale  
Termometro: Elettronico • Refrigerazione: Statica  
Gas: R290 • Luce LED con interruttore  
Serratura con chiave • 4 piedini regolabili  
Colore esterno: Grigio silver  
2 ripiani fissi (372 x 273 mm)

W x D x H: 500 x 483 x 1000 mm  
Display area: 0,692 smt • Climatic class: 7  
Watt: 270 • Energy consumption (24h): 1,81 kW  
Gross capacity: 79 lt • Net capacity: 57 lt  
Thermostat: Electronic • Defrosting: Manual  
Thermometer: Electronic • Refrigeration: Static  
Gas: R290 • LED light with switch  
Key lock • 4 adjustable feet  
Body colour: Silver Grey  
2 fixed shelves (372 x 273 mm)



## A RICHIESTA • OPTIONAL

Grafica su mobile e/o vetro frontale  
Graphic on body and/or front glass

*Duerighedesign*

# POP 50

-15°/-23° C

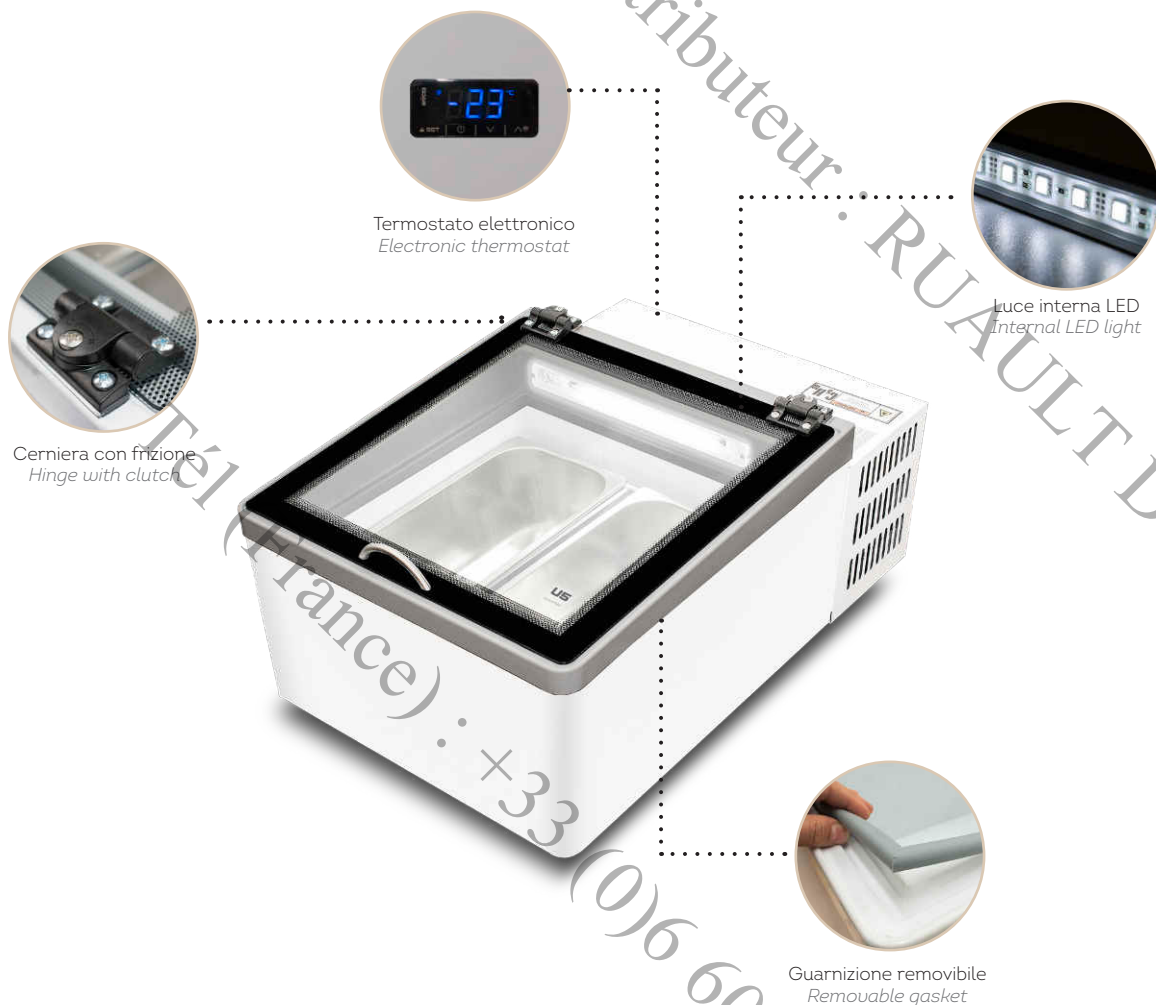

L x P x H: 505 x 760 x 382 mm  
Area visibile: 0,16 mq • Classe climatica: 7  
Watt: 100 • Consumo energetico (24h): 1,79 kW  
Capacità lorda: 33 lt • Capacità netta: 22 lt  
Termostato: Elettronico • Sbrinamento: Manuale  
Termometro: Elettronico • Refrigerazione: Statica  
Gas: R600a • Luce LED con interruttore  
4 piedini regolabili • Colore esterno: Bianco  
Vaschette non incluse

W x D x H: 505 x 760 x 382 mm  
Display area: 0,16 smt • Climatic class: 7  
Watt: 100 • Energy consumption (24h): 1,79 kW  
Gross capacity: 33 lt • Net capacity: 22 lt  
Thermostat: Electronic • Defrosting: Manual  
hermometer: Electronic • Refrigeration: Static  
Gas: R600a • LED light with switch  
4 adjustable feet • Body colour: White  
Bins not included



#### A RICHIESTA • OPTIONAL

Grafica su mobile • Kit porta ghiaccioli trasparente • Vaschette inox 5 lt o 2,5 lt  
Graphic on body • Transparent stick holder set • Stainless steel bins 5 lt or 2,5 lt

# POP 60

-15°/-23° C

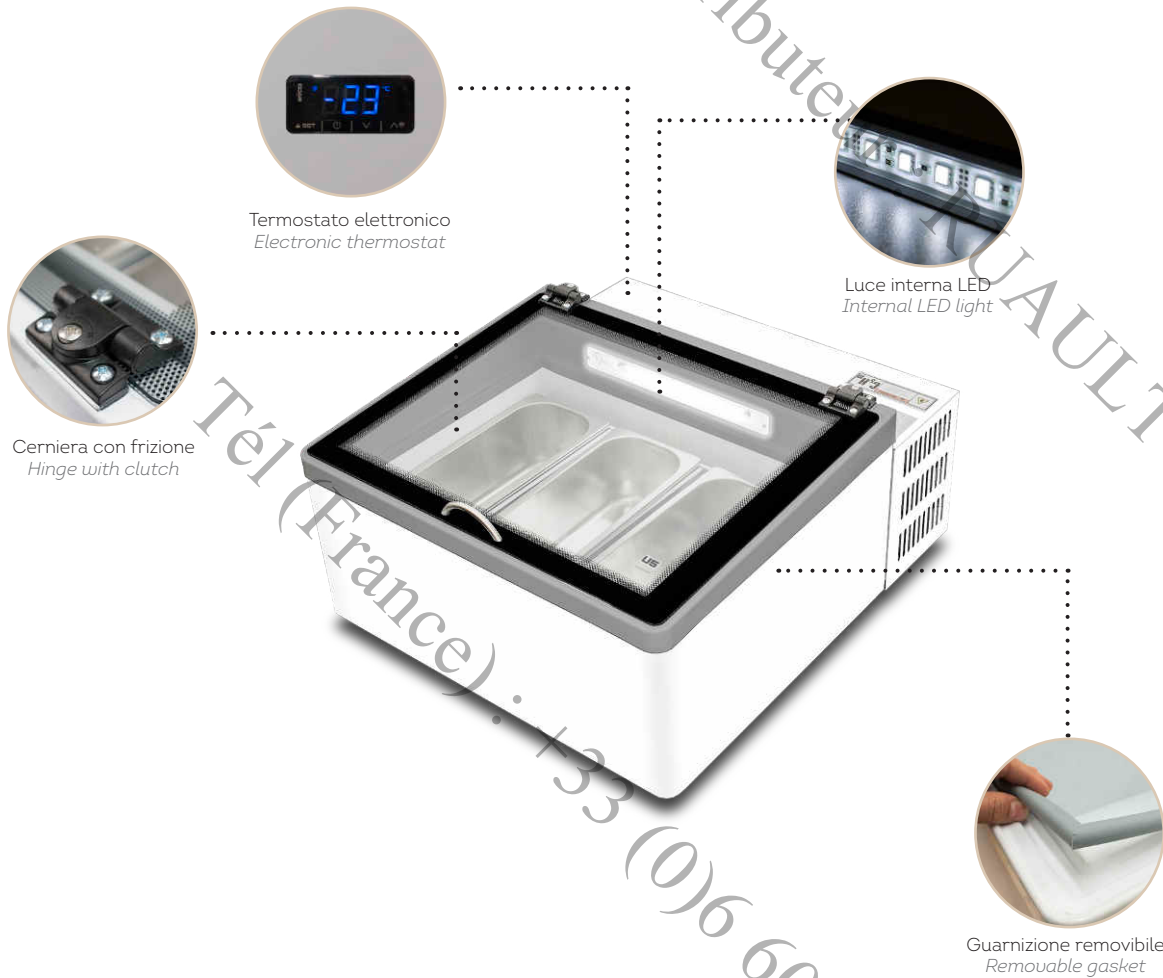

L x P x H: 680 x 760 x 382 mm  
Area visibile: 0,23 mq • Classe climatica: 7  
Watt: 150 • Consumo energetico (24h): 2,50 kW  
Capacità lorda: 50 lt • Capacità netta: 33 lt  
Termostato: Elettronico • Sbrinamento: Manuale  
Termometro: Elettronico • Refrigerazione: Statica  
Gas: R600a • Luce LED con interruttore  
4 piedini regolabili • Colore esterno: Bianco  
Vaschette non incluse

W x D x H: 680 x 760 x 382 mm  
Display area: 0,23 smt • Climatic class: 7  
Watt: 150 • Energy consumption (24h): 2,50 kW  
Gross capacity: 50 lt • Net capacity: 33 lt  
Thermostat: Electronic • Defrosting: Manual  
hermometer: Electronic • Refrigeration: Static  
Gas: R600a • LED light with switch  
4 adjustable feet • Body colour: White  
Bins not included



## A RICHIESTA • OPTIONAL

Grafica su mobile • Kit porta ghiaccioli trasparente • Vaschette inox 5 lt o 2,5 lt  
Graphic on body • Transparent stick holder set • Stainless steel bins 5 lt or 2,5 lt

# POP 365 • 50

-18°/-23° C



Cerniera con frizione  
Hinge with clutch



Luce interna LED  
Internal LED light



Guarnizione removibile  
Removable gasket

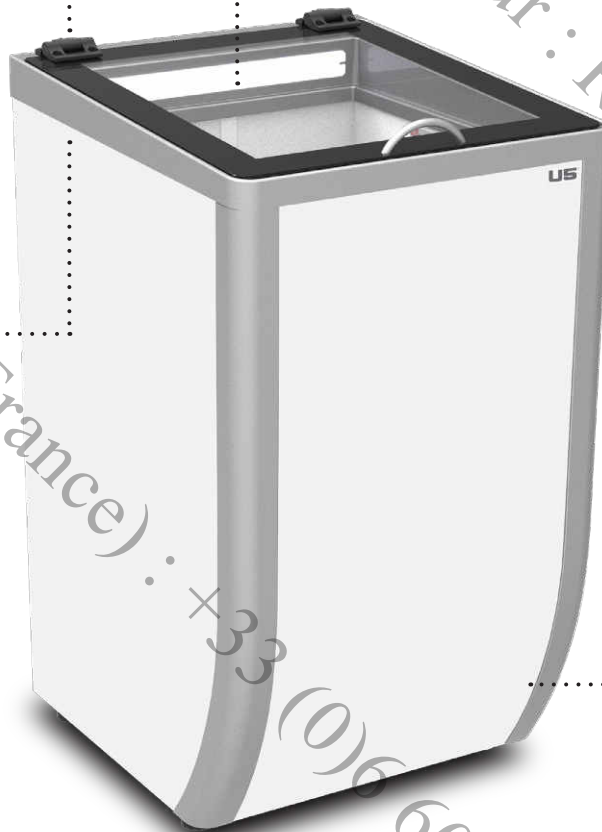

Termostato elettronico  
Electronic thermostat

L x P x H: 505 x 555 x 980 mm  
Area visibile: 0,159 mq • Classe climatica: 7  
Watt: 180 • Consumo energetico (24h): 2,52 kW  
Capacità lorda: 63 lt • Capacità netta: 57 lt  
Termostato: Elettronico • Sbrinamento: Manuale  
Termometro: Elettronico • Refrigerazione: Statica  
Gas: R600a • Luce LED con interruttore  
4 piedini regolabili • Colore esterno: Bianco e grigio

W x D x H: 505 x 555 x 980 mm  
Display area: 0,159 smt • Climatic class: 7  
Watt: 180 • Energy consumption (24h): 1,66 kW  
Gross capacity: 63 lt • Net capacity: 57 lt  
Thermostat: Electronic • Defrosting: Manual  
Thermometer: Electronic • Refrigeration: Static  
Gas: R600a • LED light with switch  
4 adjustable feet • Body colour: White and Grey



## A RICHIESTA • OPTIONAL

Grafica su mobile • Kit porta ghiaccioli trasparente  
Graphic on body • Transparent stick holder set

*Duerighedesign*

# JOKER

-18°/-23° C



Cerniera con frizione  
Hinge with clutch



Luce interna LED  
Internal LED light



Guarnizione removibile  
Removable gasket



Termostato elettronico  
Electronic thermostat

L x P x H: 866 x 360 x 904 mm  
Area visibile: 0,143 mq • Classe climatica: 4  
Watt: 100 • Consumo energetico (24h): 1,79 kW  
Capacità lorda: 61 lt • Capacità netta: 54 lt  
Termostato: Elettronico • Sbrinamento: Manuale  
Termometri: Elettronico e meccanico  
Refrigerazione: Statica  
Gas: R600a • Luce LED con interruttore  
2 piedini regolabili + 2 rullini  
Colore esterno: Bianco

W x D x H: 866 x 360 x 904 mm  
Display area: 0,143 smt • Climatic class: 4  
Watt: 100 • Energy consumption (24h): 1,79 kW  
Gross capacity: 61 lt • Net capacity: 54 lt  
Thermostat: Electronic • Defrosting: Manual  
Thermometer: Electronic and mechanic  
Refrigeration: Static  
Gas: R600a • LED light with switch  
2 adjustable feet + 2 roller  
Body colour: White



## A RICHIESTA • OPTIONAL

Grafica su mobile  
Graphic on body

DESIGN BY  
smartdesign

# KAPPA 100

-18°/-23° C



Luce interna LED  
Internal LED light



Interruttore luci display  
Display light switch



Ruote pivotanti  
Pivoting wheels



L x P x H x H: 580 x 690 (725) x 841 (1138) mm  
Area visibile: 0,241 mq • Classe climatica: 7  
Watt: 90 • Consumo energetico (24h): 1,20 kW  
Capacità lorda: 130 lt • Capacità netta: 120 lt  
Termostato: Meccanico • Sbrinamento: Manuale  
Termometro: Meccanico • Refrigerazione: Statica  
Gas: R600a • Luce LED con interruttore  
2 ruote pivotanti + 2 ruote pivotanti con freno  
Serratura con chiave • Colore esterno: Bianco  
2 cestelli

W x D x H: 580 x 690 (725) x 841 (1138) mm  
Display area: 0,241 smt • Climatic class: 7  
Watt: 90 • Energy consumption (24h): 1,20 kW  
Gross capacity: 130 lt • Net capacity: 120 lt  
Thermostat: Mechanic • Defrosting: Manual  
Thermometer: Mechanic • Refrigeration: Static  
Gas: R600a • LED light with switch  
2 pivoting wheels + 2 pivoting wheels with brake  
Key lock • Body colour: White  
2 baskets



## A RICHIESTA • OPTIONAL

Grafica su mobile e display luminoso  
Graphic on body and backlit display

# KAPPA 200

-18°/-23° C



Luce interna LED  
Internal LED light



Ruote pivotanti  
Pivoting wheels

L x P x H x H: 796 x 690 x 785 mm  
Area visibile: 0,360 mq • Classe climatica: 7  
Watt: 200 • Consumo energetico (24h): 1,80 kW  
Capacità lorda: 187 lt • Capacità netta: 144 lt  
Termostato: Meccanico • Sbrinamento: Manuale  
Termometro: Meccanico • Refrigerazione: Statica  
Gas: R600a • Luce LED con interruttore  
2 ruote pivotanti + 2 ruote pivotanti con freno  
Serratura con chiave • Colore esterno: Bianco  
2 cestelli

W x D x H: 796 x 690 x 785 mm  
Display area: 0,360 smt • Climate class: 7  
Watt: 200 • Energy consumption (24h): 1,80 kW  
Gross capacity: 187 lt • Net capacity: 144 lt  
Thermostat: Mechanic • Defrosting: Manual  
Thermometer: Mechanic • Refrigeration: Static  
Gas: R600a • LED light with switch  
2 pivoting wheels + 2 pivoting wheels with brake  
Key lock • Body colour: White  
2 baskets



## A RICHIESTA • OPTIONAL

Grafica su mobile • Display luminoso  
Graphic on body • Backlit display

# CIS AT

-18°/-23° C

Votre distributeur : RUVAULT Design



Serratura con chiave  
Key lock



Luce interna LED  
Internal LED light



Ruote pivotanti  
Pivoting wheels



Classe climatica: 7 • Termostato: Meccanico  
Sbrinamento: Manuale • Termometro: Meccanico  
Refrigerazione: Statica • Gas: R290  
Luce LED con interruttore • Serratura con chiave  
4 ruote pivotanti  
Colore esterno: Bianco e grigio

Climatic class: 7 • Thermostat: Mechanic  
Defrosting: Manual • Thermometer: Mechanic  
Refrigeration: Static • Gas: R290  
LED light with switch • Key lock  
4 pivoting wheels  
Body colour: White and grey

	CIS 160 AT	CIS 260 AT	CIS 360 AT	CIS 460 AT
<b>L x P x H (mm)</b> W x D x H	665 x 715 x 875	990 x 715 x 875	1260 x 715 x 875	1530 x 715 x 875
<b>Watt/Consumo energetico (24h)</b> Watt/Energy consumption	150 W/ 1,20 kW	170 W/ 1,45 kW	200 W/ 2,10 kW	270 W/ 2,75 kW
<b>Volume lordo/netto</b> Gross/Net capacity	150/110 lt	260/190 lt	360/260 lt	460/330 lt
<b>Cestelli</b> Baskets	2	3	4	5



**A RICHIESTA • OPTIONAL**

Grafica su mobile  
Graphic on body

# CIS VT

## -18°/-23° C

Votre distributeur : RUAULT Design

ICE CREAM  
ESPOSITORI GELATO IMPULSO IMPULSE ICE CREAM CABINETS



Serratura con chiave  
Key lock



Ruote pivotanti  
Pivoting wheels



Classe climatica: 7 • Termostato: Meccanico  
Sbrinatorio: Manuale • Termometro: Meccanico  
Refrigerazione: Statica • Gas: R290  
Serratura con chiave • 4 ruote pivotanti  
Colore esterno: Bianco e grigio  
Coperchi intercambiabili ciechi - vetro

*Climatic class: 7 • Thermostat: Mechanic  
Defrosting: Manual • Thermometer: Mechanic  
Refrigeration: Static • Gas: R290  
Key lock • 4 pivoting wheels  
Body colour: White and grey  
Interchangeable blind - glass lids*

	CIS 160 VT	CIS 260 VT	CIS 360 VT	CIS 460 VT
<b>L x P x H (mm)</b> <i>W x D x H</i>	665 x 715 x 875	990 x 715 x 875	1260 x 715 x 875	1530 x 715 x 875
<b>Watt/Consumo energetico (24h)</b> <i>Watt/Energy consumption</i>	150 W/1,10 kW	170 W/1,30 kW	200 W/1,80 kW	270 W/2,20 kW
<b>Volume lordo/netto</b> <i>Gross/Net capacity</i>	150/120 lt	260/210 lt	360/290 lt	460/370 lt
<b>Cestelli</b> <i>Baskets</i>	2	3	4	5



### A RICHIESTA • OPTIONAL

Grafica su mobile  
Graphic on body

# CIS CC

## -18°/-23° C

Votre distributeur : RUAULT Design



Serratura con chiave  
Key lock



Ruote pivotanti  
Pivoting wheels



Classe climatica: 7 • Termostato: Meccanico  
Sbrinamento: Manuale • Termometro: Meccanico  
Refrigerazione: Statica • Gas: R290  
Serratura con chiave • 4 ruote pivotanti  
Colore esterno: Bianco e grigio  
Coperchi intercambiabili ciechi - vetro

Climatic class: 7 • Thermostat: Mechanic  
Defrosting: Manual • Thermometer: Mechanic  
Refrigeration: Static • Gas: R290  
Key lock • 4 pivoting wheels  
Body colour: White and grey  
Interchangeable blind - glass lids

	CIS 160 CC	CIS 260 CC	CIS 360 CC	CIS 460 CC
<b>L x P x H (mm)</b> W x D x H	665 x 715 x 875	990 x 715 x 875	1260 x 715 x 875	1530 x 715 x 875
<b>Watt/Consumo energetico (24h)</b> Watt/Energy consumption	150 W/0,85 kW	170 W/1,05 kW	200 W/1,25 kW	270 W/1,73 kW
<b>Volume lordo/netto</b> Gross/Net capacity	150/120 lt	260/210 lt	360/290 lt	460/370 lt
<b>Cestelli</b> Baskets	2	3	4	5



**A RICHIESTA • OPTIONAL**

Grafica su mobile  
Graphic on body

# VINTAGE 200 VT

-18°/-23° C



Ruote pivotanti  
Pivoting wheels

L x P x H: 1068 x 700 x 900 mm  
Area visibile: 0,425 mq • Classe climatica: 7  
Watt: 90 • Consumo energetico (24h): 0,82 kW  
Capacità lorda: 265 lt • Capacità netta: 211 lt  
Termostato: Meccanico • Sbrinamento: Manuale  
Termometro: Meccanico • Refrigerazione: Statica  
Gas: R 290 • 4 ruote pivotanti  
Colore esterno: Bianco caldo  
Design patented: Patent N° 002674283-0002

W x D x H: 1068 x 700 x 900 mm  
Display area: 0,425 smt • Climatic class: 7  
Watt: 90 • Energy consumption (24h): 0,82 kW  
Gross capacity: 265 lt • Net capacity: 211 lt  
Thermostat: Mechanic • Defrosting: Manual  
Thermometer: Mechanic • Refrigeration: Static  
Gas: R 290 • 4 pivoting wheels  
Body colour: Warm white  
Design patented: Patent N° 002674283-0002



**A RICHIESTA • OPTIONAL**  
Grafica su mobile • Cestelli  
Graphic on body • Baskets

DESIGN BY  
**smartdesign**

# VINTAGE 300 VT

-18°/-23° C



Ruote pivotanti  
Pivoting wheels

L x P x H: 1318 x 700 x 900 mm  
 Area visibile: 0,55 mq • Classe climatica: 7  
 Watt: 160 • Consumo energetico (24h): 1,37 kW  
 Capacità lorda: 350 lt • Capacità netta: 288 lt  
 Termostato: Meccanico • Sbrinamento: Manuale  
 Termometro: Meccanico • Refrigerazione: Statica  
 Gas: R 290 • 4 ruote pivotanti  
 Colore esterno: Bianco caldo  
 Design patented: Patent N° 002674283-0002

W x D x H: 1318 x 700 x 900 mm  
 Display area: 0,55 smt • Climatic class: 7  
 Watt: 160 • Energy consumption (24h): 1,37 kW  
 Gross capacity: 350 lt • Net capacity: 288 lt  
 Thermostat: Mechanic • Defrosting: Manual  
 Thermometer: Mechanic • Refrigeration: Static  
 Gas: R 290 • 4 pivoting wheels  
 Body colour: Warm white  
 Design patented: Patent N° 002674283-0002



**A RICHIESTA • OPTIONAL**

Grafica su mobile • Cestelli  
 Graphic on body • Baskets

DESIGN BY  
**smartdesign**

# BMAX 400 AT RT

-18°/-23° C



L x P x H: 1258 x 738 x 1040 mm  
Watt: 284 • Consumo energetico (24h): 4,70 kW  
Area visibile: 0,59 mq • Classe climatica: 5  
Capacità lorda: 430 lt • Capacità netta: 386 lt  
Capacità netta riserva: 108 lt  
Termostato: Elettronico • Sbrinamento: Manuale  
Termometro: Elettronico • Refrigerazione: Statica  
Gas: R 290 • Vano riserva con cestello  
2 ruote pivotanti + 2 ruote pivotanti con freno  
Colore esterno: Bianco

W x D x H: 1258 x 738 x 1040 mm  
Watt: 284 • Energy consumption (24h): 4,70 kW  
Display area: 0,59 smt • Climatic class: 5  
Gross capacity: 430 lt • Net capacity: 386 lt  
Net capacity reserve: 108 lt  
Thermostat: Electronic • Defrosting: Manual  
Thermometer: Electronic • Refrigeration: Static  
Gas: R 290 • Storage cell with basket  
2 pivoting wheels + 2 pivoting wheels with brake  
Body colour: White



**A RICHIESTA • OPTIONAL**  
Grafica su mobile • Cestelli  
Graphic on body • Baskets

DESIGN BY  
**smartdesign**

# BMAX 680 AT RT

-18°/-23° C



Vano riserva  
Storage cell



Ruote pivotanti  
Pivoting wheels

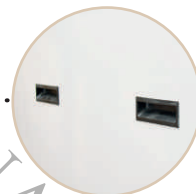

Maniglie  
Handles



Termostato elettronico  
Electronic thermostat

L x P x H: 1510 x 738 x 1040 mm  
 Watt: 380 • Consumo energetico (24h): 5,38 kW  
 Area visibile: 0,730 mq • Classe climatica: 5  
 Capacità lorda: 587 lt • Capacità netta: 479 lt  
 Capacità netta riserva: 147 lt  
 Termostato: Elettronico • Sbrinamento: Manuale  
 Termometro: Elettronico • Refrigerazione: Statica  
 Gas: R 290 • Vano riserva con cestello  
 2 ruote pivotanti + 2 ruote pivotanti con freno  
 Colore esterno: Bianco

W x D x H: 1510 x 738 x 1040 mm  
 Watt: 380 • Energy consumption (24h): 5,38 kW  
 Display area: 0,730 smt • Climatic class: 5  
 Gross capacity: 587 lt • Net capacity: 479 lt  
 Net capacity reserve: 147 lt  
 Thermostat: Electronic • Defrosting: Manual  
 Thermometer: Electronic • Refrigeration: Static  
 Gas: R 290 • Storage cell with basket  
 2 pivoting wheels + 2 pivoting wheels with brake  
 Body colour: White



**A RICHIESTA • OPTIONAL**

Grafica su mobile • Cestelli aggiuntivi  
 Graphic on body • Additional baskets

DESIGN BY  
**smartdesign**

# BMAX 680 VT RT

-18°/-23° C



L x P x H: 1519 x 789 x 1038 mm  
Classe climatica: 5 • Watt: 370  
Consumo energetico (24h): 4,80 kW  
Capacità lorda: 677 lt • Capacità netta: 544 lt  
Capacità netta riserva: 160 lt  
Termostato: Elettronico • Sbrinamento: Manuale  
Termometro: Elettronico • Gas: R290  
Serratura con chiave  
2 ruote pivotanti + 2 ruote pivotanti con freno  
Colore esterno: Bianco  
Coperchi intercambiabili ciechi - vetro

W x D x H: 1519 x 789 x 1038 mm  
Climatic class: 5 • Watt: 370  
Energy consumption (24h): 4,80 kW  
Gross capacity: 677 lt • Net capacity: 544 lt  
Net capacity reserve: 160 lt  
Thermostat: Electronic • Defrosting: Manual  
Thermometer: Electronic • Gas: R290  
Key lock  
2 pivoting wheels + 2 pivoting wheels with brake  
Body colour: White  
Interchangeable blind - glass lids



## A RICHIESTA • OPTIONAL

Grafica su mobile • Cestelli aggiuntivi  
Graphic on body • Additional baskets

DESIGN BY  
**smartdesign**

# BMAX 680 CC RT

-18°/-23° C



Vano riserva  
Storage cell



Maniglie  
Handles



Termostato elettronico  
Electronic thermostat



Ruote pivotanti  
Pivoting wheels

L x P x H: 1519 x 789 x 1038 mm  
 Classe climatica: 5 • Watt: 280  
 Consumo energetico (24h): 2,30 kW  
 Capacità lorda: 677 lt • Capacità netta: 544 lt  
 Capacità netta riserva: 160 lt  
 Termostato: Elettronico • Sbrinamento: Manuale  
 Termometro: Elettronico • Gas: R290  
 Serratura con chiave  
 2 ruote pivotanti + 2 ruote pivotanti con freno  
 Colore esterno: Bianco  
 Coperchi intercambiabili ciechi - vetro

W x D x H: 1519 x 789 x 1038 mm  
 Climatic class: 5 • Watt: 280  
 Energy consumption (24h): 2,30 kW  
 Gross capacity: 677 lt • Net capacity: 544 lt  
 Net capacity reserve: 160 lt  
 Thermostat: Electronic • Defrosting: Manual  
 Thermometer: Electronic • Gas: R290  
 Key lock  
 2 pivoting wheels + 2 pivoting wheels with brake  
 Body colour: White  
 Interchangeable blind - glass lids



**A RICHIESTA • OPTIONAL**

Grafica su mobile  
Graphic on body

DESIGN BY  
**smartdesign**

# BMAX 400 GLAMOUR

-18°/-23° C



Vano riserva  
Storage cell



Luce interna LED  
Internal LED light

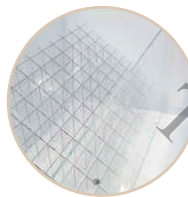

Kit porta ghiaccioli  
trasparente  
Transparent stick  
holder set

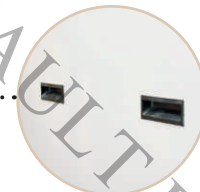

Maniglie  
Handles



Ruote pivotanti  
Pivoting wheels



Termostato elettronico  
Electronic thermostat

L x P x H: 1258 x 738 x 935 mm  
 Classe climatica: 5 • Watt: 440  
 Consumo energetico (24h): 7,26 kW  
 Capacità lorda: 402 lt • Capacità netta: 324 lt  
 Capacità netta riserva: 107 lt  
 Termostato: Elettronico • Sbrinamento: Manuale  
 Termometro: Elettronico • Gas: R290  
 2 ruote pivotanti + 2 ruote pivotanti con freno  
 Colore esterno: Grigio silver

W x D x H: 1258 x 738 x 935 mm  
 Climatic class: 5 • Watt: 440  
 Energy consumption (24h): 7,26 kW  
 Gross capacity: 402 lt • Net capacity: 324 lt  
 Net capacity reserve: 107 lt  
 Thermostat: Electronic • Defrosting: Manual  
 Thermometer: Electronic • Gas: R290  
 2 pivoting wheels + 2 pivoting wheels with brake  
 Body colour: Silver gray



**A RICHIESTA • OPTIONAL**  
 Grafica su mobile  
 Graphic on body

DESIGN BY  
**smartdesign**

ICE CREAM  
 ESPOSITORI GELATO IMPULSO IMPULSE ICE CREAM CABINETS

contact@groupe-ruault.com

# KRYO 42 NV

-18°/-23° C



Serratura con chiave  
Key lock



Termostato elettronico  
Electronic thermostat



Luce interna LED  
Internal LED light



L x P x H: 602 x 672 x 1886 mm  
Area visibile: 0,76 mq • Classe climatica: 7  
Capacità lorda: 331 lt • Capacità netta: 266 lt  
Termostato: Elettronico • Sbrinamento: Automatico  
Refrigerazione: Ventilata • Gas: R 290  
Luce LED interna • Serratura con chiave  
2 piedini regolabili + 2 rullini  
Colore esterno: Grigio silver  
4 griglie (455 x 405 mm)

W x D x H: 602 x 672 x 1886 mm  
Display area: 0,76 smt • Climatic class: 7  
Gross capacity: 331 lt • Net capacity: 266 lt  
Thermostat: Electronic • Defrosting: Automatic  
Refrigeration: Ventilated • Gas: R 290  
Internal LED light • Key lock  
2 adjustable feet + 2 rollers  
Body colour: Silver Grey  
4 shelves (455 x 405 mm)



**A RICHIESTA • OPTIONAL**

Grafica su mobile e/o vetro frontale • Kit porta ghiaccioli trasparente • Cestelli  
Graphic on body and/or front glass • Transparent stick holder set • Baskets

# FROST 180 ns

-18°/-23° C



Serratura con chiave  
Key lock



Luce interna LED  
Internal LED light



Termostato elettronico  
Electronic thermostat

L x P x H: 400 x 574 x 1848 mm  
Area visibile: 0,41 mq • Classe climatica: 7  
Watt: 297 • Consumo energetico (24h): 4,71 kW  
Capacità lorda: 170 lt • Capacità netta: 130 lt  
Termostato: Elettronico • Sbrinamento: Manuale  
Termometro: Elettronico  
Refrigerazione: Statica • Gas: R 290  
Luce LED interna • Serratura con chiave  
2 piedini regolabili + 4 rullini  
Colore esterno: Grigio silver  
Brevetto N° 202016000004507

W x D x H: 400 x 574 x 1848 mm  
Display area: 0,41 smt • Climatic class: 7  
Watt: 297 • Energy consumption (24h): 4,71 kW  
Gross capacity: 170 lt • Net capacity: 130 lt  
Thermostat: Electronic • Defrosting: Manual  
Thermometer: Electronic  
Refrigeration: Static • Gas: R 290  
Internal LED light • Key lock  
2 adjustable feet + 4 rollers  
Body colour: Silver Grey  
Patent N° 202016000004507



## A RICHIESTA • OPTIONAL

Grafica su mobile e/o vetro frontale • Kit porta ghiaccioli trasparente • Cestelli  
Graphic on body and/or front glass • Transparent stick holder set • Baskets

DESIGN BY  
**smartdesign**

# FROST 250 NS

-18°/-23° C



Serratura con chiave  
Key lock



Luce interna LED  
Internal LED light



Termostato elettronico  
Electronic thermostat

L x P x H: 452 x 701 x 1848 mm  
Area visibile: 0,49 mq • Classe climatica: 7  
Watt: 504 • Consumo energetico (24h): 6,90 kW  
Capacità lorda: 252 lt • Capacità netta: 190 lt  
Termostato: Elettronico • Sbrinamento: Manuale  
Termometro: Elettronico  
Refrigerazione: Statica • Gas: R 290  
Luce LED interna • Serratura con chiave  
2 piedini regolabili + 4 rullini  
Colore esterno: Grigio silver  
Brevetto N° 202016000004507

W x D x H: 452 x 701 x 1848 mm  
Display area: 0,49 smt • Climatic class: 7  
Watt: 504 • Energy consumption (24h): 6,90 kW  
Gross capacity: 252 lt • Net capacity: 190 lt  
Thermostat: Electronic • Defrosting: Manual  
Thermometer: Electronic  
Refrigeration: Static • Gas: R 290  
Internal LED light • Key lock  
2 adjustable feet + 4 rollers  
Body colour: Silver Grey  
Patent N° 202016000004507



**A RICHIESTA • OPTIONAL**

Grafica su mobile e/o vetro frontale • Kit porta ghiaccioli trasparente • Cestelli  
Graphic on body and/or front glass • Transparent stick holder set • Baskets

DESIGN BY  
**smartdesign**

# FROST GLAMOUR 250 NS

-18°/-23° C



Votre distributeur : R...ULT Design

ICE CREAM  
VETRINE VERTICALI • VERTICAL DISPLAY FREEZER



Serratura con chiave  
Key lock

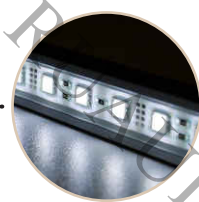

Luce interna LED  
Internal LED light



Termostato elettronico  
Electronic thermostat

L x P x H: 452 x 701 x 1848 mm  
Area visibile: 1,28 mq • Classe climatica: 5  
Watt: 610 • Consumo energetico (24h): 9,50 kW  
Capacità lorda: 252 lt • Capacità netta: 190 lt  
Termostato: Elettronico • Sbrinamento: Manuale  
Termometro: Elettronico  
Refrigerazione: Statica • Gas: R 290  
Luce LED interna • Serratura con chiave  
2 piedini regolabili + 4 rullini  
Colore esterno: Grigio silver  
Brevetto N° 003718717-0001  
Brevetto N° 202017000003906

W x D x H: 452 x 701 x 1848 mm  
Display area: 1,28 smt • Climatic class: 5  
Watt: 610 • Energy consumption (24h): 9,50 kW  
Gross capacity: 252 lt • Net capacity: 190 lt  
Thermostat: Electronic • Defrosting: Manual  
Thermometer: Electronic  
Refrigeration: Static • Gas: R 290  
Internal LED light • Key lock  
2 adjustable feet + 4 rollers  
Body colour: Silver Grey  
Patent N° 003718717-0001  
Patent N° 202017000003906

contact@Groupe-ruault.com



**A RICHIESTA • OPTIONAL**  
Grafica su mobile e/o vetro frontale • Kit porta ghiaccioli trasparente • Cestelli  
Graphic on body and/or front glass • Transparent stick holder set • Baskets

DESIGN BY  
**smartdesign**

# FROST 250 NV SD

-18°/-23° C



Serratura con chiave  
Key lock



Luce interna LED  
Internal LED light



Termostato elettronico  
Electronic thermostat

L x P x H: 452 x 701 x 1848 mm  
Area visibile: 0,43 mq • Classe climatica: 7  
Watt: 450 • Consumo energetico (24h): 6,79 kW  
Capacità lorda: 245 lt • Capacità netta: 147 lt  
Termostato: Elettronico • Sbrinamento: Manuale  
Termometro: Elettronico • Refrigerazione: Ventilata  
Gas: R 290 • Luce LED interna  
Serratura con chiave • 2 piedini regolabili + 4 rullini  
Colore esterno: Grigio silver  
4 griglie (287 x 450 mm)  
Brevetto N° 202016000004507

W x D x H: 452 x 701 x 1848 mm  
Display area: 0,43 smt • Climatic class: 7  
Watt: 450 • Energy consumption (24h): 6,79 kW  
Gross capacity: 245 lt • Net capacity: 147 lt  
Thermostat: Electronic • Defrosting: Manual  
Thermometer: Electronic • Refrigeration: Ventilated  
Gas: R 290 • Internal LED light  
Key lock • 2 adjustable feet + 4 rollers  
Body colour: Silver Grey  
2 shelves (287 x 450 mm)  
Patent N° 202016000004507



## A RICHIESTA • OPTIONAL

Grafica su mobile e/o vetro frontale • Kit porta ghiaccioli trasparente • Cestelli  
Graphic on body and/or front glass • Transparent stick holder set • Baskets

DESIGN BY  
**smartdesign**

# FROST 280 NS SD

-18°/-23° C



Serratura con chiave  
Key lock



Luce interna LED  
Internal LED light



Termostato elettronico  
Electronic thermostat

L x P x H: 540 x 646 x 1788 mm  
Area visibile: 0,47 mq • Classe climatica: 7  
Watt: 540 • Consumo energetico (24h): 6,95 kW  
Capacità lorda: 283 lt • Capacità netta: 185 lt  
Termostato: Elettronico  
Sbrinamento: Manuale  
Termometro: Elettronico  
Refrigerazione: Statica • Gas: R 290  
Luce LED interna • Serratura con chiave  
2 piedini regolabili + 4 rullini  
Colore esterno: Grigio silver  
Brevetto N° 202016000004507

W x D x H: 540 x 646 x 1788 mm  
Display area: 0,47 smt • Climatic class: 7  
Watt: 540 • Energy consumption (24h): 6,95 kW  
Gross capacity: 283 lt • Net capacity: 185 lt  
Thermostat: Electronic  
Defrosting: Manual  
Thermometer: Electronic  
Refrigeration: Static • Gas: R 290  
Internal LED light • Key lock  
2 adjustable feet + 4 rollers  
Body colour: Silver Grey  
Patent N° 202016000004507



## A RICHIESTA • OPTIONAL

Grafica su mobile e/o vetro frontale • Kit porta ghiaccioli trasparente • Cestelli  
Graphic on body and/or front glass • Transparent stick holder set • Baskets

DESIGN BY  
**smartdesign**

# FROST 350 ns

-18°/-23° C



Serratura con chiave  
Key lock



Termostato elettronico  
Electronic thermostat

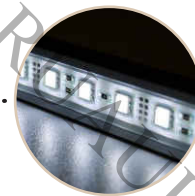

Luce interna LED  
Internal LED light

L x P x H: 610 x 639 x 1844 mm  
Area visibile: 0,69 smt • Classe climatica: 7  
Watt: 585 • Consumo energetico (24h): 7,00 kW  
Capacità lorda: 320 lt • Capacità netta: 255 lt  
Termostato: Elettronico • Sbrinamento: Manuale  
Termometro: Elettronico  
Refrigerazione: Statica • Gas: R 290  
Luce LED interna • Serratura con chiave  
2 piedini regolabili + 4 rullini  
Colore esterno: Grigio silver  
Brevetto N° 202016000004507

W x D x H: 610 x 639 x 1844 mm  
Display area: 0,69 smt • Climatic class: 7  
Watt: 585 • Energy consumption (24h): 7,00 kW  
Gross capacity: 320 lt • Net capacity: 255 lt  
Thermostat: Electronic • Defrosting: Manual  
Thermometer: Electronic  
Refrigeration: Statica/Static • Gas: R 290  
Internal LED light • Key lock  
2 adjustable feet + 4 rollers  
Body colour: Silver Grey  
Patent N° 202016000004507



## A RICHIESTA • OPTIONAL

Grafica su mobile e/o vetro frontale • Kit porta ghiaccioli trasparente • Cestelli  
Graphic on body and/or front glass • Transparent stick holder set • Baskets

DESIGN BY  
**smartdesign**

# FROST 350 ns SD

-18°/-23° C



Serratura con chiave  
Key lock

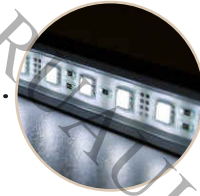

Luce interna LED  
Internal LED light



Termostato elettronico  
Electronic thermostat

L x P x H: 610 x 639 x 1844 mm  
Area visibile: 0,69 smt • Classe climatica: 7  
Watt: 585 • Consumo energetico (24h): 7,00 kW  
Capacità lorda: 323 lt • Capacità netta: 248 lt  
Termostato: Elettronico • Sbrinamento: Manuale  
Termometro: Eelettronico  
Refrigerazione: Statica • Gas: R 290  
Luce LED interna • Serratura con chiave  
2 piedini regolabili + 4 rullini  
Colore esterno: Grigio silver

W x D x H: 610 x 639 x 1844 mm  
Display area: 0,69 smt • Climatic class: 7  
Watt: 585 • Energy consumption (24h): 7,00 kW  
Gross capacity: 323 lt • Net capacity: 248 lt  
Thermostat: Electronic • Defrosting: Manual  
Thermometer: Electronic  
Refrigeration: Statica/Static • Gas: R 290  
Internal LED light • Key lock  
2 adjustable feet + 4 rollers  
Body colour: Silver Grey



## A RICHIESTA • OPTIONAL

Grafica su mobile e/o vetro frontale • Kit porta ghiaccioli trasparente • Cestelli  
Graphic on body and/or front glass • Transparent stick holder set • Baskets

DESIGN BY  
**smartdesign**

# FROST GLAMOUR NS 350

-18°/-23° C



Serratura con chiave  
Key lock

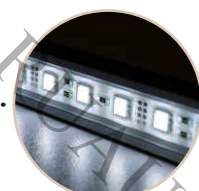

Luce interna LED  
Internal LED light



Termostato elettronico  
Electronic thermostat

L x P x H: 610 x 639 x 1844 mm  
 Area visibile: 1,31 smt • Classe climatica: 5  
 Watt: 720 • Consumo energetico (24h): 11,93 kW  
 Capacità lorda: 320 lt • Capacità netta: 255 lt  
 Termostato: Elettronico • Sbrinamento: Manuale  
 Termometro: Elettronico  
 Refrigerazione: Statica • Gas: R 290  
 Luce LED interna • Serratura con chiave  
 2 piedini regolabili + 4 rullini  
 Colore esterno: Grigio silver  
 Brevetto N° 003718717-0001  
 Brevetto N° 202017000003906

W x D x H: 610 x 639 x 1844 mm  
 Display area: 1,35 smt • Climatic class: 5  
 Watt: 720 • Energy consumption (24h): 11,93 kW  
 Gross capacity: 320 lt • Net capacity: 255 lt  
 Thermostat: Electronic • Defrosting: Manual  
 Thermometer: Electronic  
 Refrigeration: Static • Gas: R 290  
 Internal LED light • Key lock  
 2 adjustable feet + 4 rollers  
 Body colour: Silver Grey  
 Patent N° 003718717-0001  
 Patent N° 202017000003906



**A RICHIESTA • OPTIONAL**

Grafica su mobile e/o vetro frontale • Kit porta ghiaccioli trasparente • Cestelli  
 Graphic on body and/or front glass • Transparent stick holder set • Baskets

DESIGN BY  
**smartdesign**

# FROST 400 ns

-18°/-23° C



ICE CREAM  
VETRINE VERTICALI • VERTICAL DISPLAY FREEZER



Serratura con chiave  
Key lock

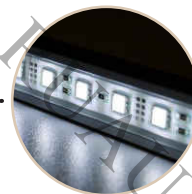

Luce interna LED  
Internal LED light



Termostato elettronico  
Electronic thermostat



Termostato elettronico  
Electronic thermostat

L x P x H: 670 x 644 x 2000 mm  
Area visibile: 0,75 smt • Classe climatica: 7  
Watt: 630 • Consumo energetico (24h): 10,96 kW  
Capacità lorda: 415 lt • Capacità netta: 310 lt  
Termostato: Elettronico • Sbrinamento: Manuale  
Termometro: Elettronico  
Refrigerazione: Statica • Gas: R 290  
Luce LED interna • Serratura con chiave  
2 piedini regolabili + 4 rullini  
Colore esterno: Grigio silver  
Brevetto N° 202016000004507

W x D x H: 670 x 644 x 2000 mm  
Display area: 0,75 smt • Climatic class: 7  
Watt: 630 • Energy consumption (24h): 10,96 kW  
Gross capacity: 415 lt • Net capacity: 310 lt  
Thermostat: Electronic • Defrosting: Manual  
Thermometer: Electronic  
Refrigeration: Statica/Static • Gas: R 290  
Internal LED light • Key lock  
2 adjustable feet + 4 rollers  
Body colour: Silver Grey  
Patent N° 202016000004507



## A RICHIESTA • OPTIONAL

Grafica su mobile e/o vetro frontale • Kit porta ghiaccioli trasparente • Cestelli  
Graphic on body and/or front glass • Transparent stick holder set • Baskets

DESIGN BY  
**smartdesign**

# FROST 400 ns SD

-18°/-23° C



Serratura con chiave  
Key lock

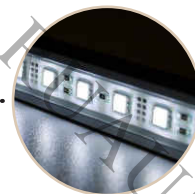

Luce interna LED  
Internal LED light



Termostato elettronico  
Electronic thermostat

L x P x H: 670 x 644 x 2000 mm  
Area visibile: 0,75 smt • Classe climatica: 7  
Watt: 630 • Consumo energetico (24h): 10,96 kW  
Capacità lorda: 415 lt • Capacità netta: 310 lt  
Termostato: Elettronico • Sbrinamento: Manuale  
Termometro: Elettronico  
Refrigerazione: Statica • Gas: R 290  
Luce LED interna • Serratura con chiave  
2 piedini regolabili + 4 rullini  
Colore esterno: Grigio silver

W x D x H: 670 x 644 x 2000 mm  
Display area: 0,75 smt • Climatic class: 7  
Watt: 630 • Energy consumption (24h): 10,96 kW  
Gross capacity: 415 lt • Net capacity: 310 lt  
Thermostat: Electronic • Defrosting: Manual  
Thermometer: Electronic  
Refrigeration: Statica/Static • Gas: R 290  
Internal LED light • Key lock  
2 adjustable feet + 4 rollers  
Body colour: Silver Grey



## A RICHIESTA • OPTIONAL

Grafica su mobile e/o vetro frontale • Kit porta ghiaccioli trasparente • Cestelli  
Graphic on body and/or front glass • Transparent stick holder set • Baskets

DESIGN BY  
**smartdesign**

# FROST GLAMOUR NS 400

-18°/-23° C



Serratura con chiave  
Key lock

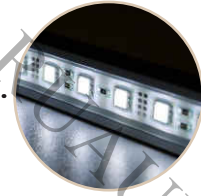

Luce interna LED  
Internal LED light



Termostato elettronico  
Electronic thermostat

L x P x H: 670 x 644 x 2000 mm  
Area visibile: 1,5 mq • Classe climatica: 5  
Watt: 760 • Consumo energetico (24h): 13,45 kW  
Capacità lorda: 415 lt • Capacità netta: 310 lt  
Termostato: Elettronico • Sbrinamento: Manuale  
Termometro: Elettronico  
Refrigerazione: Statica • Gas: R 290  
Luce LED interna • Serratura con chiave  
2 piedini regolabili + 4 rullini  
Colore esterno: Grigio silver  
Brevetto N° 003718717-0001  
Brevetto N° 202017000003906

W x D x H: 670 x 644 x 2000 mm  
Display area: 1,5 smt • Climatic class: 5  
Watt: 760 • Energy consumption (24h): 13,45 kW  
Gross capacity: 415 lt • Net capacity: 310 lt  
Thermostat: Electronic • Defrosting: Manual  
Thermometer: Electronic  
Refrigeration: Static • Gas: R 290  
Internal LED light • Key lock  
2 adjustable feet + 4 rollers  
Body colour: Silver Grey  
Patent N° 003718717-0001  
Patent N° 202017000003906



## A RICHIESTA • OPTIONAL

Grafica su mobile e/o vetro frontale • Kit porta ghiaccioli trasparente • Cestelli  
Graphic on body and/or front glass • Transparent stick holder set • Baskets

DESIGN BY  
**smartdesign**

# FROST 400 NV

-18°/-23° C



Serratura con chiave  
Key lock

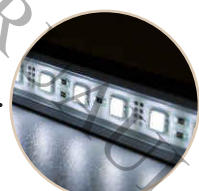

Luce interna LED  
Internal LED light



Termostato elettronico  
Electronic thermostat

L x P x H: 670 x 644 x 2000 mm  
Area visibile: 0,77 smt • Classe climatica: 7  
Capacità lorda: 415 lt • Capacità netta: 295 lt  
Termostato: Elettronico • Sbrinamento: Automatico  
Termometro: Elettronico  
Refrigerazione: Ventilata • Gas: R 290  
Luce LED interna • Serratura con chiave  
2 piedini regolabili + 4 rullini  
Colore esterno: Grigio silver  
4 griglie (540 x 393 mm) + 1 di fondo (514 x 393 mm)  
Brevetto N° 202016000004507

W x D x H: 670 x 644 x 2000 mm  
Display area: 0,75 smt • Climatic class: 7  
Gross capacity: 415 lt • Net capacity: 295 lt  
Thermostat: Electronic • Defrosting: Automatico  
Thermometer: Electronic  
Refrigeration: Ventilated • Gas: R 290  
Internal LED light • Key lock  
2 adjustable feet + 4 rollers  
Body colour: Silver Grey  
4 griglie (540 x 393 mm) + 1 di fondo (514 x 393 mm)  
Patent N° 202016000004507



**A RICHIESTA • OPTIONAL**

Grafica su mobile e/o vetro frontale • Kit porta ghiaccioli trasparente • Cestelli  
Graphic on body and/or front glass • Transparent stick holder set • Baskets

DESIGN BY  
**smartdesign**

# FROST 400 NV SD

-18°/-23° C



Serratura con chiave  
Key lock



Luce interna LED  
Internal LED light



Termostato elettronico  
Electronic thermostat

L x P x H: 670 x 644 x 2000 mm  
Area visibile: 0,77 smt • Classe climatica: 7  
Capacità lorda: 415 lt • Capacità netta: 295 lt  
Termostato: Elettronico • Sbrinamento: Automatico  
Termometro: Elettronico  
Refrigerazione: Ventilata • Gas: R 290  
Luce LED interna • Serratura con chiave  
2 piedini regolabili + 4 rullini  
Colore esterno: Grigio silver  
4 griglie (540 x 393 mm) + 1 di fondo (514 x 393 mm)

W x D x H: 670 x 644 x 2000 mm  
Display area: 0,75 smt • Climatic class: 7  
Gross capacity: 415 lt • Net capacity: 295 lt  
Thermostat: Electronic • Defrosting: Automatic  
Thermometer: Electronic  
Refrigeration: Ventilated • Gas: R 290  
Internal LED light • Key lock  
2 adjustable feet + 4 rollers  
Body colour: Silver Grey  
4 grilles (540 x 393 mm) + 1 di fondo (514 x 393 mm)



## A RICHIESTA • OPTIONAL

Grafica su mobile e/o vetro frontale • Kit porta ghiaccioli trasparente • Cestelli  
Graphic on body and/or front glass • Transparent stick holder set • Baskets

DESIGN BY  
**smartdesign**

# FROST 350 PS

+2°/+8° C



Serratura con chiave  
Key lock



Luce interna LED  
Internal LED light



Termostato elettronico  
Electronic thermostat

L x P x H: 610 x 639 x 1844 mm  
 Area visibile: 0,69 mq • Classe climatica: 7  
 Watt: 180 • Consumo energetico (24h): 2,72 kW  
 Capacità lorda: 320 lt • Capacità netta: 230 lt  
 Termostato: Elettronico • Sbrinamento: Automatico  
 Termometro: Elettronico  
 Refrigerazione: Statica • Gas: R 290  
 Luce LED interna • Serratura con chiave  
 2 piedini regolabili + 4 rullini  
 Colore esterno: Grigio silver  
 4 griglie (460 x 405 mm) + 1 di fondo (460 x 430 mm)  
 Brevetto N° 202016000004507

W x D x H: 610 x 639 x 1844 mm  
 Display area: 0,69 smt • Climatic class: 7  
 Watt: 180 • Energy consumption (24h): 2,72 kW  
 Gross capacity: 320 lt • Net capacity: 230 lt  
 Thermostat: Electronic • Defrosting: Automatic  
 Thermometer: Electronic  
 Refrigeration: Static • Gas: R 290  
 Internal LED light • Key lock  
 2 adjustable feet + 4 rollers  
 Body colour: Silver Grey  
 4 grilles (460 x 405 mm) + 1 di fondo (460 x 430 mm)  
 Patent N° 202016000004507



**A RICHIESTA • OPTIONAL**  
 Grafica su mobile e/o vetro frontale  
 Graphic on body and/or front glass

DESIGN BY  
**smartdesign**

# FROST 350 PS SD

+2°/+8° C



Serratura con chiave  
Key lock



Luce interna LED  
Internal LED light



Termostato elettronico  
Electronic thermostat

L x P x H: 610 x 639 x 1844 mm  
Area visibile: 0,69 mq • Classe climatica: 7  
Watt: 180 • Consumo energetico (24h): 2,72 kW  
Capacità lorda: 320 lt • Capacità netta: 230 lt  
Termostato: Elettronico • Sbrinamento: Automatico  
Termometro: Elettronico  
Refrigerazione: Statica • Gas: R 290  
Luce LED interna • Serratura con chiave  
2 piedini regolabili + 4 rullini  
Colore esterno: Grigio silver  
4 griglie (460 x 405 mm) + 1 di fondo (460 x 430 mm)

W x D x H: 610 x 639 x 1844 mm  
Display area: 0,69 smt • Climatic class: 7  
Watt: 180 • Energy consumption (24h): 2,72 kW  
Gross capacity: 320 lt • Net capacity: 230 lt  
Thermostat: Electronic • Defrosting: Automatic  
Thermometer: Electronic  
Refrigeration: Static • Gas: R 290  
Internal LED light • Key lock  
2 adjustable feet + 4 rollers  
Body colour: Silver Grey  
4 grilles (460 x 405 mm) + 1 di fondo (460 x 430 mm)



## A RICHIESTA • OPTIONAL

Grafica su mobile e/o vetro frontale  
Graphic on body and/or front glass

DESIGN BY  
**smartdesign**

# FROST GLAMOUR 350 PS

+2°/+8° C



Serratura con chiave  
Key lock



Luce interna LED  
Internal LED light



Termostato elettronico  
Electronic thermostat

L x P x H: 610 x 639 x 1844 mm  
 Area visibile: 1,35 mq • Classe climatica: 5  
 Watt: 200 • Consumo energetico (24h): 4,25 kW  
 Capacità lorda: 320 lt • Capacità netta: 230 lt  
 Termostato: Elettronico • Sbrinamento: Automatico  
 Termometro: Elettronico  
 Refrigerazione: Statica • Gas: R 290  
 Luce LED interna • Serratura con chiave  
 2 piedini regolabili + 4 rullini  
 Colore esterno: Grigio silver  
 4 griglie (460 x 405 mm) + 1 di fondo (460 x 430 mm)  
 Brevetto N° 003718717-0001  
 Brevetto N° 202017000003906

W x D x H: 610 x 639 x 1844 mm  
 Display area: 1,35 smt • Climatic class: 5  
 Watt: 200 • Energy consumption (24h): 4,25 kW  
 Gross capacity: 320 lt • Net capacity: 230 lt  
 Thermostat: Electronic • Defrosting: Automatic  
 Thermometer: Electronic  
 Refrigeration: Static • Gas: R 290  
 Internal LED light • Key lock  
 2 adjustable feet + 4 rollers  
 Body colour: Silver Grey  
 4 grilles (460 x 405 mm) + 1 di fondo (460 x 430 mm)  
 Patent N° 003718717-0001  
 Patent N° 202017000003906



## A RICHIESTA • OPTIONAL

Grafica su mobile e/o vetro frontale  
Graphic on body and/or front glass

DESIGN BY  
**smartdesign**

# FROST 400 PS

+2°/+8° C



Serratura con chiave  
Key lock

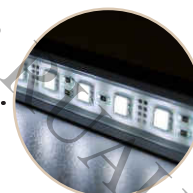

Luce interna LED  
Internal LED light



Termostato elettronico  
Electronic thermostat

L x P x H: 670 x 644 x 2000 mm  
Area visibile: 0,77 smt • Classe climatica: 7  
Watt: 235 • Consumo energetico (24h): 4,60 kW  
Capacità lorda: 415 lt • Capacità netta: 310 lt  
Termostato: Elettronico • Sbrinamento: Automatico  
Termometro: Elettronico  
Refrigerazione: Statica • Gas: R 600a  
Luce LED interna • Serratura con chiave  
2 piedini regolabili + 4 rullini  
Colore esterno: Grigio silver  
4 griglie (540 x 393 mm) + 1 di fondo (514 x 393 mm)  
Brevetto N° 202016000004507

W x D x H: 670 x 644x 2000 mm  
Display area: 0,77 smt • Climatic class: 7  
Watt: 235 • Energy consumption (24h): 4,60 kW  
Gross capacity: 415 lt • Net capacity: 310 lt  
Thermostat: Electronic • Defrosting: Automatic  
Thermometer: Electronic  
Refrigeration: Static • Gas: R 600a  
Internal LED light • Key lock  
2 adjustable feet + 4 rollers  
Body colour: Silver Grey  
4 griglie (540 x 393 mm) + 1 di fondo (514 x 393 mm)  
Patent N° 202016000004507



## A RICHIESTA • OPTIONAL

Grafica su mobile e/o vetro frontale  
Graphic on body and/or front glass

DESIGN BY  
**smartdesign**

# FROST 400 PS SD

+2°/+8° C



Serratura con chiave  
Key lock

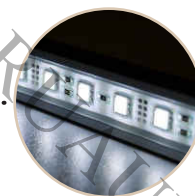

Luce interna LED  
Internal LED light



Termostato elettronico  
Electronic thermostat

L x P x H: 670 x 644 x 2000 mm  
 Area visibile: 0,77 smt • Classe climatica: 7  
 Watt: 235 • Consumo energetico (24h): 4,60 kW  
 Capacità lorda: 415 lt • Capacità netta: 310 lt  
 Termostato: Elettronico • Sbrinamento: Automatico  
 Termometro: Elettronico  
 Refrigerazione: Statica • Gas: R 600a  
 Luce LED interna • Serratura con chiave  
 2 piedini regolabili + 4 rullini  
 Colore esterno: Grigio silver  
 4 griglie (540 x 393 mm) + 1 di fondo (514 x 393 mm)

W x D x H: 670 x 644 x 2000 mm  
 Display area: 0,77 smt • Climatic class: 7  
 Watt: 235 • Energy consumption (24h): 4,60 kW  
 Gross capacity: 415 lt • Net capacity: 310 lt  
 Thermostat: Electronic • Defrosting: Automatic  
 Thermometer: Electronic  
 Refrigeration: Static • Gas: R 600a  
 Internal LED light • Key lock  
 2 adjustable feet + 4 rollers  
 Body colour: Silver Grey  
 4 grilles (540 x 393 mm) + 1 di fondo (514 x 393 mm)



## A RICHIESTA • OPTIONAL

Grafica su mobile e/o vetro frontale  
 Graphic on body and/or front glass

DESIGN BY  
**smartdesign**

# VERTICAL VINTAGE 350

-18°/-23° C



Luce interna LED  
Internal LED light

L x P x H: 620 x 688 x 1931 mm  
Area visibile: 0,56 mq • Classe climatica: 7  
Watt: 585 • Consumo energetico (24h): 7,00 kW  
Capacità lorda: 320 lt • Capacità netta: 255 lt  
Termostato: Elettronico • Sbrinamento: Manuale  
Termometro: Elettronico e meccanico  
Refrigerazione: Statica • Gas: R 290  
Luce LED interna  
2 piedini regolabili + 4 rullini  
Colore esterno: Bianco caldo  
Brevetto di design N° 002674283-0005  
Brevetto N° 202016000004507

W x D x H: 620 x 688 x 1931 mm  
Display area: 0,56 smt • Climatic class: 7  
Watt: 585 • Energy consumption (24h): 7,00 kW  
Gross capacity: 320 lt • Net capacity: 255 lt  
Thermostat: Electronic • Defrosting: Manual  
Thermometer: Electronic and mechanic  
Refrigeration: Static • Gas: R 290  
Internal LED light  
2 adjustable feet + 4 rollers  
Body colour: Warm white  
Design patented: Patent N° 002674283-0005  
Patent N° 202016000004507



## A RICHIESTA • OPTIONAL

Grafica su mobile e/o vetro frontale • Kit porta ghiaccioli trasparente • Cestelli  
Graphic on body and/or front glass • Transparent stick holder set • Baskets

DESIGN BY  
**smartdesign**

# VERTICAL VINTAGE 400

-18°/-23° C



Luce interna LED  
Internal LED light

L x P x H: 690 x 693 x 2086 mm  
Area visibile: 0,75 mq • Classe climatica: 7  
Watt: 630 • Consumo energetico (24h): 10,96 kW  
Capacità lorda: 415 lt • Capacità netta: 310 lt  
Termostato: Elettronico • Sbrinamento: Manuale  
Termometro: Elettronico e meccanico  
Refrigerazione: Statica • Gas: R 290  
Luce LED interna  
2 piedini regolabili + 4 rullini  
Colore esterno: Bianco caldo  
Brevetto di design N° 002674283-0005  
Brevetto N° 202016000004507

W x D x H: 690 x 693 x 2086 mm  
Display area: 0,75 smt • Climatic class: 7  
Watt: 630 • Energy consumption (24h): 10,96 kW  
Gross capacity: 415 lt • Net capacity: 310 lt  
Thermostat: Electronic • Defrosting: Manual  
Thermometer: Electronic and mechanic  
Refrigeration: Static • Gas: R 290  
Internal LED light  
2 adjustable feet + 4 rollers  
Body colour: Warm white  
Design patented: Patent N° 002674283-0005  
Patent N° 202016000004507



#### A RICHIESTA • OPTIONAL

Grafica su mobile e/o vetro frontale • Kit porta ghiaccioli trasparente • Cestelli  
Graphic on body and/or front glass • Transparent stick holder set • Baskets

DESIGN BY  
**smartdesign**

# GLAMOUR TOWER W

-18°/-23° C



ICE CREAM  
VETRINE VERTICALI • VERTICAL DISPLAY FREEZER



Ripiani in vetro  
Glass shelf



Luce interna LED  
Internal LED light



Serratura con chiave  
Key lock



Termostato elettronico  
Electronic thermostat



L x P x H: 680 x 695 x 2000 mm  
Area visibile: 1,56 mq • Classe climatica: 5  
Capacità lorda: 416 lt • Capacità netta: 325 lt  
Termostato: Elettronico • Sbrinamento: Automatico  
Refrigerazione: Ventilata • Gas: R 290  
4 luci LED interne • Serratura con chiave  
2 piedini regolabili + 4 rullini  
Colore esterno: Bianco  
Brevetto N° 003718717-0001  
Brevetto N° 202017000003906

W x D x H: 680 x 695 x 2000 mm  
Display area: 1,56 smt • Climatic class: 5  
Gross capacity: 416 lt • Net capacity: 325 lt  
Thermostat: Electronic • Defrosting: Automatic  
Refrigeration: Ventilated • Gas: R 290  
4 internal LED light • Key lock  
2 adjustable feet + 4 rollers  
Body colour: White  
Patent N° 003718717-0001  
Patent N° 202017000003906



## A RICHIESTA • OPTIONAL

Grafica su mobile e/o vetro frontale • Kit porta ghiaccioli trasparente • Cestelli  
Graphic on body and/or front glass • Transparent stick holder set • Baskets

*Duerighedesign*

# GLAMOUR TOWER B

-18°/-23° C



Ripiani in vetro  
Glass shelf



Luce interna LED  
Internal LED light



Serratura con chiave  
Key lock



Termostato elettronico  
Electronic thermostat

L x P x H: 680 x 695 x 2000 mm  
Area visibile: 1,56 mq • Classe climatica: 5  
Capacità lorda: 416 lt • Capacità netta: 325 lt  
Termostato: Elettronico • Sbrinamento: Automatico  
Refrigerazione: Ventilata • Gas: R 290  
4 luci LED interne • Serratura con chiave  
2 piedini regolabili + 4 rullini  
Colore esterno: Nero  
Brevetto N° 003718717-0001  
Brevetto N° 202017000003906

W x D x H: 680 x 695 x 2000 mm  
Display area: 1,56 smt • Climatic class: 5  
Gross capacity: 416 lt • Net capacity: 325 lt  
Thermostat: Electronic • Defrosting: Automatic  
Refrigeration: Ventilated • Gas: R 290  
4 internal LED light • Key lock  
2 adjustable feet + 4 rollers  
Body colour: Black  
Patent N° 003718717-0001  
Patent N° 202017000003906



## A RICHIESTA • OPTIONAL

Grafica su mobile e/o vetro frontale • Kit porta ghiaccioli trasparente • Cestelli  
Graphic on body and/or front glass • Transparent stick holder set • Baskets

*Duerighedesign*

# GLAMOUR TOWER G

-18°/-23° C



ICE CREAM  
VETRINE VERTICALI • VERTICAL DISPLAY FREEZER



Ripiani in vetro  
Glass shelf



Luce interna LED  
Internal LED light



Serratura con chiave  
Key lock



Termostato elettronico  
Electronic thermostat

L x P x H: 680 x 695 x 2000 mm  
Area visibile: 1,56 mq • Classe climatica: 5  
Capacità lorda: 416 lt • Capacità netta: 325 lt  
Termostato: Elettronico • Sbrinamento: Automatico  
Refrigerazione: Ventilata • Gas: R 290  
4 luci LED interne • Serratura con chiave  
2 piedini regolabili + 4 rullini  
Colore esterno: Grigio silver  
Brevetto N° 003718717-0001  
Brevetto N° 202017000003906

W x D x H: 680 x 695 x 2000 mm  
Display area: 1,56 smt • Climatic class: 5  
Gross capacity: 416 lt • Net capacity: 325 lt  
Thermostat: Electronic • Defrosting: Automatic  
Refrigeration: Ventilated • Gas: R 290  
4 internal LED light • Key lock  
2 adjustable feet + 4 rollers  
Body colour: Silver Grey  
Patent N° 003718717-0001  
Patent N° 202017000003906



## A RICHIESTA • OPTIONAL

Grafica su mobile e/o vetro frontale • Kit porta ghiaccioli trasparente • Cestelli  
Graphic on body and/or front glass • Transparent stick holder set • Baskets

*Duerighedesign*

# TWIN 40

+2°/+8° C -18°/-25° C



Serratura con chiave  
Key lock



Luce interna LED  
Internal LED light



Termostato elettronico  
Electronic thermostat

L x P x H: 680 x 645 x 2000 mm  
Area visibile: 0,72 mq • Classe climatica: 7  
Termostato: Elettronico • Termometro: Elettronico  
Sbrinamento: Manuale • Refrigerazione: Statica  
Luce LED interna • Gas: R 600a  
2 piedini regolabili + 4 rullini  
Colore esterno: Grigio silver • 2 serrature con chiave  
Temperatura positiva  
Capacità lorda: 208 lt • Capacità netta: 128 lt  
2 griglie (533 x 400 mm) + 1 di fondo (520 x 385 mm)  
Temperatura negativa  
Capacità lorda: 180 lt • Capacità netta: 136 lt  
2 ripiani fissi

W x D x H: 680 x 645 x 2000 mm  
Display area: 0,72 smt • Climatic class: 7  
Thermostat: Electronic • Thermometer: Electronic  
Defrosting: manual • Refrigeration: Static  
Internal LED light • Gas: R600a  
2 adjustable feet + 4 rollers  
Body colour: Silver Grey • 2 locks with key  
Positive temperature  
Gross capacity: 208 lt • Net capacity: 128 lt  
2 shelves(533 x 400 mm) + 1 bottom (520 x 385 mm)  
Negative temperature  
Gross capacity: 180 lt • Net capacity: 136 lt  
2 fixed shelves



**A RICHIESTA • OPTIONAL**

Grafica su mobile e/o vetro frontale • Cestelli  
Graphic on body and/or front glass • Baskets

# TRECARAPINE

-5°/-20° C



Ruote pivotanti  
Pivoting wheels



Termostato elettronico  
Electronic thermostat

L x P x H: 1007 x 561 x 948 mm

Classe climatica: 7

Watt: 150 • Consumo energetico (24h): 0,95 kW

Capacità lorda: 138 lt • Capacità netta: 132 lt

Termostato: Elettronico

Sbrinamento: Manuale • Termometro: Elettronico

Refrigerazione: Statica • Gas: R 600a

Colore esterno: Bianco e grigio

2 ruote pivotanti + 2 ruote pivotanti con freno

Carapine 7,5 lt (non include): N° 3

W x D x H: 1007 x 561 x 948 mm

Climatic class: 7

Watt: 150 • Energy consumption (24h): 0,95 kW

Gross capacity: 138 lt • Net capacity: 132 lt

Thermostat: Electronic

Defrosting: Manual • Thermometer: Electronic

Refrigeration: Static • Gas: R 600a

Body colour: White and gray

2 pivoting wheels + 2 pivoting wheels with brake

Cylindrical tubs 7,5 lt (not included): Nr 3



## A RICHIESTA • OPTIONAL

Grafica su mobile • Kit lavaporzionatore • Porta coni • Carapine (7,5 litri)

Graphic on body • Scoop-washer kit • Cone holder • Cylindrical tubs (7,5 Lt)

# VIA VENETO 4C

-5°/-20° C



Ruote pivotanti  
Pivoting wheels



Termostato elettronico  
Electronic thermostat

L x P x H: 818 x 690 x 984 (1257\*) mm  
 Classe climatica: 7  
 Watt: 120 • Consumo energetico (24h): 0,80 kW  
 Capacità lorda: 156 lt • Capacità netta: 135 lt  
 Termostato: Elettronico • Sbrinamento: Manuale  
 Termometro: Elettronico e meccanico  
 Refrigerazione: Statica • Gas: R 600a  
 Colore esterno: Bianco caldo  
 2 ruote pivotanti + 2 ruote pivotanti con freno  
 Carapine 7,5 lt (non include): N° 4 + 2 riserva  
 Brevetto di design N° 002674283-0007

W x D x H: 818 x 690 x 984 (1257\*) mm  
 Climatic class: 7  
 Watt: 120 • Energy consumption (24h): 0,80 kW  
 Gross capacity: 156 lt • Net capacity: 135 lt  
 Thermostat: Electronic • Defrosting: Manual  
 Thermometer: Electronic and mechanic  
 Refrigeration: Static • Gas: R 600a  
 Body colour: Warm white  
 2 pivoting wheels + 2 pivoting wheels with brake  
 Cylindrical tubs 7,5 lt (not included): Nr 4 + 2 as storage  
 DESIGN PATENTED: PATENT N° 002674283-0007



## A RICHIESTA • OPTIONAL

Grafica su mobile • Kit lavaporzizzatore • Porta coni • Carapine (7,5 litri) • Plexi frontale (\*)  
 Graphic on body • Scoop-washer kit • Cone holder • Cylindrical tubs (7,5 Lt) • Front plexi (\*)

DESIGN BY  
**smartdesign**

# VIA VENETO 6C

-5°/-20° C



Ruote pivotanti  
Pivoting wheels



Termostato elettronico  
Electronic thermostat

L x P x H: 1068 x 690 x 984 (1257\*) mm  
Classe climatica: 7  
Watt: 140 • Consumo energetico (24h): 0,85 kW  
Capacità lorda: 265 lt • Capacità netta: 211 lt  
Termostato: Elettronico • Sbrinamento: Manuale  
Termometro: Elettronico e meccanico  
Refrigerazione: Statica • Gas: R 600a  
Colore esterno: Bianco caldo  
2 ruote pivotanti + 2 ruote pivotanti con freno  
Carapine 7,5 lt (non incluse): N° 6 + 4 riserva  
Brevetto di design N° 002674283-0007

W x D x H: 1068 x 690 x 984 (1257\*) mm  
Climatic class: 7  
Watt: 140 • Energy consumption (24h): 0,85 kW  
Gross capacity: 265 lt • Net capacity: 211 lt  
Thermostat: Electronic • Defrosting: Manual  
Thermometer: Electronic and mechanic  
Refrigeration: Static • Gas: R 600a  
Body colour: Warm white  
2 pivoting wheels + 2 pivoting wheels with brake  
Cylindrical tubs 7,5 lt (not included): Nr 6 + 4 as storage  
DESIGN PATENTED: PATENT N° 002674283-0007



## A RICHIESTA • OPTIONAL

Grafica su mobile • Kit lavaporzizzatore • Porta coni • Carapine (7,5 litri) • Plexi frontale (\*)  
Graphic on body • Scoop-washer kit • Cone holder • Cylindrical tubs (7,5 Lt) • Front plexi (\*)

DESIGN BY  
**smartdesign**

# VIA VENETO 8C

-5°/-20° C



Ruote pivotanti  
Pivoting wheels



Termostato elettronico  
Electronic thermostat

L x P x H: 1318 x 690 x 984 (1257\*) mm  
 Classe climatica: 7  
 Watt: 160 • Consumo energetico (24h): 0,94 kW  
 Capacità lorda: 350 lt • Capacità netta: 288 lt  
 Termostato: Elettronico  
 Sbrinamento: Manuale • Termometro: Meccanico  
 Refrigerazione: Statica • Gas: R 600a  
 Colore esterno: Bianco caldo  
 2 ruote pivotanti + 2 ruote pivotanti con freno  
 Carapine 7,5 lt (non incluse): N° 8 + 6 riserva  
 Brevetto di design N° 002674283-0007

W x D x H: 1318 x 690 x 984 (1257\*) mm  
 Climatic class: 7  
 Watt: 160 • Energy consumption (24h): 0,94 kW  
 Gross capacity: 350 lt • Net capacity: 288 lt  
 Thermostat: Electronic  
 Defrosting: Manual • Thermometer: Mechanic  
 Refrigeration: Static • Gas: R 600a  
 Body colour: Warm white  
 2 pivoting wheels + 2 pivoting wheels with brake  
 Cylindrical tubs 7,5 lt (not included): Nr 8 + 6 as storage  
 DESIGN PATENTED: PATENT N° 002674283-0007



## A RICHIESTA • OPTIONAL

Grafica su mobile • Kit lavaporzionaore • Porta coni • Carapine (7,5 litri) • Plexi frontale (\*)  
 Graphic on body • Scoop-washer kit • Cone holder • Cylindrical tubs (7,5 Lt) • Front plexi (\*)

DESIGN BY  
**smartdesign**

# VIA VENETO COMBI 4C

-5°/-20° C



Termostato elettronico  
Electronic thermostat

L x P x H: 770 x 679 x 961 mm  
Classe climatica: 7  
Watt: 120 • Consumo energetico (24h): 0,80 kW  
Capacità lorda: 156 lt • Capacità netta: 135 lt  
Termostato: Elettronico • Sbrinamento: Manuale  
Termometro: Elettronico  
Refrigerazione: Statica • Gas: R 600a  
Colore esterno: Grigio silver  
4 piedi regolabili  
Carapine 7,5 lt (non incluse): N° 4 + 2 riserva

W x D x H: 770 x 679 x 961 mm  
Climatic class: 7  
Watt: 120 • Energy consumption (24h): 0,80 kW  
Gross capacity: 156 lt • Net capacity: 135 lt  
Thermostat: Electronic • Defrosting: Manual  
Thermometer: Electronic  
Refrigeration: Static • Gas: R 600a  
Body colour: Silver grey  
4 adjustable feet  
Cylindrical tubs 7,5 lt (not included): Nr 4 + 2 as storage



## A RICHIESTA • OPTIONAL

Kit lavaporzionatore • Porta coni • Carapine (7,5 litri)  
Scoop-washer kit • Cone holder • Cylindrical tubs (7,5 Lt)

Votre distributeur : RUVAULT Design  
Tél (France) : +33 (0)6 50 52 24 38  
contact@groupe-ruault.com

# VIA VENETO COMBI 6C

-5°/-20° C



Termostato elettronico  
Electronic thermostat

L x P x H: 1020 x 679 x 961 mm  
 Classe climatica: 7  
 Watt: 140 • Consumo energetico (24h): 0,85 kW  
 Capacità lorda: 265 lt • Capacità netta: 211 lt  
 Termostato: Elettronico • Sbrinamento: Manuale  
 Termometro: Elettronico  
 Refrigerazione: Statica • Gas: R 600a  
 Colore esterno: Grigio silver  
 4 piedi regolabili  
 Carapine 7,5 lt (non incluse): N° 6 + 4 riserva

W x D x H: 1020 x 679 x 961 mm  
 Climatic class: 7  
 Watt: 140 • Energy consumption (24h): 0,85 kW  
 Gross capacity: 265 lt • Net capacity: 211 lt  
 Thermostat: Electronic • Defrosting: Manual  
 Thermometer: Electronic  
 Refrigeration: Static • Gas: R 600a  
 Body colour: Silver grey  
 4 adjustable feet  
 Cylindrical tubs 7,5 lt (not included): Nr 6 + 4 as storage



#### A RICHIESTA • OPTIONAL

Kit lavaporzionario • Porta coni • Carapine (7,5 litri)  
 Scoop-washer kit • Cone holder • Cylindrical tubs (7,5 Lt)

# VIA VENETO COMBI 8C

-5°/-20° C



Termostato elettronico  
Electronic thermostat

L x P x H: 1270 x 679 x 961 mm  
Classe climatica: 7  
Watt: 160 • Consumo energetico (24h): 0,94 kW  
Capacità lorda: 350 lt • Capacità netta: 288 lt  
Termostato: Elettronico • Sbrinamento: Manuale  
Termometro: Elettronico  
Refrigerazione: Statica • Gas: R 600a  
Colore esterno: Grigio silver  
4 piedi regolabili  
Carapine 7,5 lt (non incluse): N° 8 + 6 riserva

W x D x H: 1270 x 679 x 961 mm  
Climatic class: 7  
Watt: 160 • Energy consumption (24h): 0,94 kW  
Gross capacity: 350 lt • Net capacity: 288 lt  
Thermostat: Electronic • Defrosting: Manual  
Thermometer: Electronic  
Refrigeration: Static • Gas: R 600a  
Body colour: Silver grey  
4 adjustable feet  
Cylindrical tubs 7,5 lt (not included): Nr 8 + 6 as storage



## A RICHIESTA • OPTIONAL

Kit lavaporzionatore • Porta coni • Carapine (7,5 litri)  
Scoop-washer kit • Cone holder • Cylindrical tubs (7,5 Lt)

# VINTAGE SCOPPING 5V

-5°/-20° C



Ruote pivotanti  
Pivoting wheels



Termostato elettronico  
Electronic thermostat

L x P x H: 1068 x 700 x 984 (1257\*) mm  
 Area visibile: 0,425 mq • Classe climatica: 7  
 Watt: 90 • Consumo energetico (24h): 0,82 kW  
 Capacità lorda: 265 lt • Capacità netta: 211 lt  
 Termostato: Elettronico • Sbrinamento: Manuale  
 Termometro: Elettronico e meccanico  
 Refrigerazione: Statica  
 Gas: R 290 • 4 ruote pivotanti  
 Colore esterno: Bianco caldo  
 Vaschette 5 lt (non incluse): N° 5 + riserva  
 Design patented: Patent N° 002674283-0002

W x D x H: 1068 x 700 x 984 (1257\*) mm  
 Display area: 0,425 smt • Climatic class: 7  
 Watt: 90 • Energy consumption (24h): 0,82 kW  
 Gross capacity: 265 lt • Net capacity: 211 lt  
 Thermostat: Electronic • Defrosting: Manual  
 Thermometer: Electronic and mechanic  
 Refrigeration: Static  
 Gas: R 290 • 4 pivoting wheels  
 Body colour: Warm white  
 Bins 5 lt (not included): Nr 5 + storage  
 Design patented: Patent N° 002674283-0002



## A RICHIESTA • OPTIONAL

Grafica su mobile • Kit lavaporzionatore • Porta coni • Vaschette (5 litri) • Plexi frontale (\*)  
 Graphic on body • Scoop-washer kit • Cone holder • Tubs (5 Lt) • Front plexi (\*)

DESIGN BY  
**smartdesign**

# VINTAGE SCOOPING 6V

-5°/-20° C



Ruote pivotanti  
Pivoting wheels



Termostato elettronico  
Electronic thermostat

L x P x H: 1318 x 700 x 984 (1257\*) mm  
Area visibile: 0,55 mq • Classe climatica: 7  
Watt: 160 • Consumo energetico (24h): 1,37 kW  
Capacità lorda: 350 lt • Capacità netta: 288 lt  
Termostato: Elettronico • Sbrinamento: Manuale  
Termometro: Elettronico e meccanico  
Refrigerazione: Statica  
Gas: R 290 • 4 ruote pivotanti  
Colore esterno: Bianco caldo  
Vaschette 5 lt (non include): N° 6 + riserva  
Design patented: Patent N° 002674283-0002

W x D x H: 1318 x 700 x 984 (1257\*) mm  
Display area: 0,55 smt • Climatic class: 7  
Watt: 160 • Energy consumption (24h): 1,37 kW  
Gross capacity: 350 lt • Net capacity: 288 lt  
Thermostat: Electronic • Defrosting: Manual  
Thermometer: Electronic and mechanic  
Refrigeration: Static  
Gas: R 290 • 4 pivoting wheels  
Body colour: Warm white  
Bins 5 lt (not included): Nr 6 + storage  
Design patented: Patent N° 002674283-0002



## A RICHIESTA • OPTIONAL

Grafica su mobile • Kit lavaporzionatore • Porta coni • Vaschette (5 litri) • Plexi frontale (\*)  
Graphic on body • Scoop-washer kit • Cone holder • Tubs (5 Lt) • Front plexi (\*)

DESIGN BY  
**smartdesign**

# EVOQUE

-5°/-20° C



## 3 LAYERS

- DISPLAY
- TEMPERING
- STORAGE



Vano riserva  
Storage cell



Ruote pivotanti  
Pivoting wheels



Luce interna LED  
Internal LED light



Termostato elettronico  
Electronic thermostat

Classe climatica: 7  
Termostato: Elettronico  
Sbrinamento: Automatico  
Termometro: Elettronico  
Refrigerazione: Statica • Gas: R 290  
Colore esterno: Nero  
2 ruote pivotanti + 2 ruote pivotanti con freno

### EVOQUE 7

L x P x H: 1380 x 704 x 1190 mm  
vaschette 5 lt (non include): N° 7 + 15 riserva

### EVOQUE 10

L x P x H: 1380 x 869 x 1190 mm  
vaschette 5 lt (non include): N° 10 + 20 riserva

### EVOQUE 13

L x P x H: 1710 x 869 x 1190 mm  
vaschette 5 lt (non include): N° 13 + 27 riserva

Climatic class: 7  
Thermostat: Electronic  
Defrosting: Automatic  
Thermometer: Electronic  
Refrigeration: Static • Gas: R 290  
Body colour: Black  
2 pivoting wheels + 2 pivoting wheels with brake

### EVOQUE 7

W x D x H: 1380 x 704 x 1190 mm  
Bins 5 lt (not included): Nr 7 + 15 as storage

### EVOQUE 10

W x D x H: 1380 x 869 x 1190 mm  
Bins 5 lt (not included): Nr 10 + 20 as storage

### EVOQUE 13

W x D x H: 1710 x 869 x 1190 mm  
Bins 5 lt (not included): Nr 13 + 27 as storage



#### A RICHIESTA • OPTIONAL

Grafica su mobile • Kit lavaporzatore • Porta coni • Vaschette (5 litri)  
Graphic on body • Scoop-washer kit • Cone holder • Tubs (5 Lt)

*Duerighedesign*

# SUPERMARCHÉ

contact@groupe-ruault.com

Tél (France) : +33

06 60 52 24 38

Votre distributeur : RUAULT Design



# SYSON 100

+3°/+6° C



L x P x H: 1020 x 700 x 1990 mm  
Area visibile: 1,08 smt • Classe climatica: 3  
Watt: 840 • Consumo energetico (24h): 12,60 kW  
Capacità lorda: 695 lt • Capacità netta: 387 lt  
Termostato: Elettronico • Sbrinamento: Automatico  
Termometro: Elettronico  
Refrigerazione: Ventilata • Gas: R290  
Luce LED con interruttore  
2 piedini regolabili  
Colore esterno: Nero

W x D x H: 1020 x 700 x 1990 mm  
Display area: 1,08 smt • Climatic class: 3  
Watt: 840 • Energy consumption (24h): 12,60 kW  
Gross capacity: 695 lt • Net capacity: 387 lt  
Thermostat: Electronic • Defrosting: Automatic  
Thermometer: Electronic  
Refrigeration: Ventilated • Gas: R290  
LED light with switch  
2 adjustable feet  
Body colour: Black



# SYSON 130

+3°/+6° C



L x P x H: 1330 x 700 x 1990 mm  
Area visibile: 1,44 smt • Classe climatica: 3  
Watt: 926 • Consumo energetico (24h): 13,90 kW  
Capacità lorda: 925 lt • Capacità netta: 515 lt  
Termostato: Elettronico • Sbrinamento: Automatico  
Termometro: Elettronico  
Refrigerazione: Ventilata • Gas: R290  
Luce LED con interruttore  
2 piedini regolabili  
Colore esterno: Nero

W x D x H: 1330 x 700 x 1990 mm  
Display area: 1,44 smt • Climatic class: 3  
Watt: 926 • Energy consumption (24h): 13,90 kW  
Gross capacity: 925 lt • Net capacity: 515 lt  
Thermostat: Electronic • Defrosting: Automatic  
Thermometer: Electronic  
Refrigeration: Ventilated • Gas: R290  
LED light with switch  
2 adjustable feet  
Body colour: Black



# SYSON 150

+3°/+6° C



L x P x H: 1530 x 700 x 1990 mm  
Area visibile: 1,67 mq • Classe climatica: 3  
Watt: 948 • Consumo energetico (24h): 18,6 kW  
Capacità lorda: 1075 lt • Capacità netta: 598 lt  
Termostato: Elettronico • Sbrinamento: Automatico  
Termometro: Elettronico  
Refrigerazione: Ventilata • Gas: R290  
Luce LED con interruttore  
2 piedini regolabili  
Colore esterno: Nero

W x D x H: 1530 x 700 x 1990 mm  
Display area: 1,67 smt • Climatic class: 3  
Watt: 948 • Energy consumption (24h): 18,6 kW  
Gross capacity: 1075 lt • Net capacity: 598 lt  
Thermostat: Electronic • Defrosting: Automatic  
Thermometer: Electronic  
Refrigeration: Ventilated • Gas: R290  
LED light with switch  
2 adjustable feet  
Body colour: Black



# GT EVO 150

-18°/-23° C



Termostato elettronico  
Electronic thermostat



L x P x H: 1520 x 944 x 848 mm  
Area visibile: 1,05 mq • Classe climatica: 7  
Watt: 340 • Consumo energetico (24h): 4,93 kW  
Capacità lorda: 564 lt • Capacità netta: 418 lt  
Termostato: Elettronico • Sbrinamento: Manuale  
Termometro: Elettronico • Refrigerazione: Statica  
Gas: R 290 • Colore esterno: Bianco  
4 piedi regolabili • Cestelli non inclusi  
Patent N° 002901405-0001

W x D x H: 1520 x 944 x 848 mm  
Display area: 1,05 smt • Climatic class: 7  
Watt: 340 • Energy consumption (24h): 4,93 kW  
Gross capacity: 564 lt • Net capacity: 418 lt  
Thermostat: Electronic • Defrosting: Manual  
Thermometer: Electronic • Refrigeration: Static  
Gas: R 290 • Body colour: White  
4 adjustable feet • Baskets not included  
Patent N° 002901405-0001



#### A RICHIESTA • OPTIONAL

Grafica su mobile • Cestelli (Max 5)  
Graphic on body • Baskets (Max 5)

DESIGN BY  
**smartdesign**

# GT EVO 200

-18°/-23° C



Termostato elettronico  
Electronic thermostat



L x P x H: 2020 x 944 x 848 mm  
Area visibile: 1,42 mq • Classe climatica: 7  
Watt: 440 • Consumo energetico (24h): 5,52 kW  
Capacità lorda: 808 lt • Capacità netta: 600 lt  
Termostato: Elettronico • Sbrinamento: Manuale  
Termometro: Elettronico • Refrigerazione: Statica  
Gas: R 290 • Colore esterno: Bianco  
4 piedi regolabili • Cestelli non inclusi  
Patent N° 002901405-0001

W x D x H: 2020 x 944 x 848 mm  
Display area: 1,42 smt • Climatic class: 7  
Watt: 440 • Energy consumption (24h): 5,52 kW  
Gross capacity: 808 lt • Net capacity: 600 lt  
Thermostat: Electronic • Defrosting: Manual  
Thermometer: Electronic • Refrigeration: Static  
Gas: R 290 • Body colour: White  
4 adjustable feet • Baskets not included  
Patent N° 002901405-0001



#### A RICHIESTA • OPTIONAL

Grafica su mobile • Cestelli (Max 7)  
Graphic on body • Baskets (Max 7)

DESIGN BY  
**smartdesign**

# GT EVO 250

-18°/-23° C



Termostato elettronico  
Electronic thermostat



L x P x H: 2520 x 944 x 848 mm  
Area visibile: 1,75 mq • Classe climatica: 7  
Watt: 480 • Consumo energetico (24h): 6,48 kW  
Capacità lorda: 1037 lt • Capacità netta: 782 lt  
Termostato: Elettronico • Sbrinamento: Manuale  
Termometro: Elettronico • Refrigerazione: Statica  
Gas: R 290 • Colore esterno: Bianco  
4 piedi regolabili • Cestelli non inclusi  
Patent N° 002901405-0001

W x D x H: 2520 x 944 x 848 mm  
Display area: 1,75 smt • Climatic class: 7  
Watt: 480 • Energy consumption (24h): 6,48 kW  
Gross capacity: 1037 lt • Net capacity: 782 lt  
Thermostat: Electronic • Defrosting: Manual  
Thermometer: Electronic • Refrigeration: Static  
Gas: R 290 • Body colour: White  
4 adjustable feet • Baskets not included  
Patent N° 002901405-0001



## A RICHIESTA • OPTIONAL

Grafica su mobile • Cestelli (Max 9)  
Graphic on body • Baskets (Max 9)

DESIGN BY  
**smartdesign**

Votre distributeur : RUVAULT Design  
Tél (France) : +33 (0)6 60 52 24 38  
contact@groupe-ruault.com

# GT EVO 150 HGD

-18°/-23° C



Termostato elettronico  
Electronic thermostat



Sbrinamento automatico  
Automatic defrosting

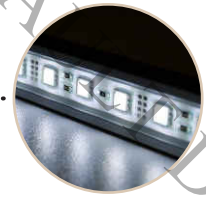

Luce interna LED  
Internal LED light

L x P x H: 1520 x 944 x 848 mm  
Area visibile: 1,05 mq • Classe climatica: 7  
Watt: 355 • Consumo energetico (24h): 5,5 kW  
Capacità lorda: 564 lt • Capacità netta: 374 lt  
Termostato: Elettronico • Sbrinamento: Automatico  
Termometro: Elettronico • Refrigerazione: Statica  
Gas: R 290 • Colore esterno: Bianco  
4 piedi regolabili • Cestelli non inclusi  
Patent N° 002901405-0001

W x D x H: 1520 x 944 x 848 mm  
Display area: 1,05 smt • Climatic class: 7  
Watt: 355 • Energy consumption (24h): 5,5 kW  
Gross capacity: 564 lt • Net capacity: 374 lt  
Thermostat: Electronic • Defrosting: Automatic  
Thermometer: Electronic • Refrigeration: Static  
Gas: R 290 • Body colour: White  
4 adjustable feet • Baskets not included  
Patent N° 002901405-0001



#### A RICHIESTA • OPTIONAL

Grafica su mobile • Cestelli (Max 5)  
Graphic on body • Baskets (Max 5)

DESIGN BY  
**smartdesign**

# GT EVO 200 HGD

-18°/-23° C



Termostato elettronico  
Electronic thermostat



Sbrinamento automatico  
Automatic defrosting

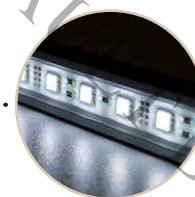

Luce interna LED  
Internal LED light

L x P x H: 2000 x 944 x 838 mm  
Area visibile: 1,46 mq • Classe climatica: 7  
Watt: 455 • Consumo energetico (24h): 6,25 kW  
Capacità lorda: 808 lt • Capacità netta: 535 lt  
Termostato: Elettronico • Sbrinamento: Automatico  
Termometro: Elettronico • Refrigerazione: Statica  
Gas: R 290 • Colore esterno: Bianco  
4 piedi regolabili • Cestelli non inclusi  
Patent N° 002901405-0001

W x D x H: 2000 x 944 x 838 mm  
Display area: 1,46 smt • Climatic class: 7  
Watt: 455 • Energy consumption (24h): 6,25 kW  
Gross capacity: 808 lt • Net capacity: 535 lt  
Thermostat: Electronic • Defrosting: Automatic  
Thermometer: Electronic • Refrigeration: Static  
Gas: R 290 • Body colour: White  
4 adjustable feet • Baskets not included  
Patent N° 002901405-0001



## A RICHIESTA • OPTIONAL

Grafica su mobile • Cestelli (Max 7)  
Graphic on body • Baskets (Max 7)

DESIGN BY  
**smartdesign**

# GT EVO 250 HGD

-18°/-23° C



Termostato elettronico  
Electronic thermostat



Luce interna LED  
Internal LED light



Sbrinamento automatico  
Automatic defrosting



L x P x H: 2520 x 944 x 848 mm  
Area visibile: 1,75 mq • Classe climatica: 7  
Watt: 495 • Consumo energetico (24h): 7,10 kW  
Capacità lorda: 1182 lt • Capacità netta: 784 lt  
Termostato: Elettronico • Sbrinamento: Automatico  
Termometro: Elettronico • Refrigerazione: Statica  
Gas: R 290 • Colore esterno: Bianco  
4 piedi regolabili • Cestelli non inclusi  
Patent N° 002901405-0001

W x D x H: 2520 x 944 x 848 mm  
Display area: 1,75 smt • Climatic class: 7  
Watt: 495 • Energy consumption (24h): 7,10 kW  
Gross capacity: 1182 lt • Net capacity: 784 lt  
Thermostat: Electronic • Defrosting: Automatic  
Thermometer: Electronic • Refrigeration: Static  
Gas: R 290 • Body colour: White  
4 adjustable feet • Baskets not included  
Patent N° 002901405-0001



## A RICHIESTA • OPTIONAL

Grafica su mobile • Cestelli (Max 9)  
Graphic on body • Baskets (Max 9)

DESIGN BY  
**smartdesign**

# PROMO 75

+2°/+4° C



Termostato elettronico  
Electronic thermostat



Ruote pivotanti  
Pivoting wheels

L x P x H: 769 x 669 x 964 mm  
Area visibile: 0,51 mq • Classe climatica: 3  
Watt: 297 • Consumo energetico (24h): 5,1 kW  
Capacità lorda: 85 lt • Capacità netta: 67 lt  
Termostato: Elettronico • Sbrinamento: Automatico  
Termometro: Elettronico • Refrigerazione: Ventilata  
Gas: R 290 • Colore esterno: Grigio silver  
2 ruote pivotanti + 2 ruote pivotanti con freno  
Batticarrello

W x D x H: 769 x 669 x 964 mm  
Display area: 0,51 smt • Climatic class: 3  
Watt: 297 • Energy consumption (24h): 5,1 kW  
Gross capacity: 85 lt • Net capacity: 67 lt  
Thermostat: Electronic • Defrosting: Automatic  
Thermometer: Electronic • Refrigeration: Ventilated  
Gas: R 290 • Body colour: Silver Grey  
2 pivoting wheels + 2 pivoting wheels with brake  
Bumper



## A RICHIESTA • OPTIONAL

Grafica su mobile  
Graphic on body

CATERING

[contact@groupe-ruault.com](mailto:contact@groupe-ruault.com)

Tél (France) : +33

Votre distributeur : RUAULT Design



96 90 53 24 38

# CHF

## -18°/-25° C



Serratura con chiave  
Key lock

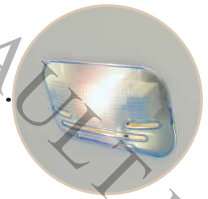

Luce interna  
Internal light

Classe climatica: 4 • Termostato: Meccanico  
Sbrinamento: Manuale • Termometro: Meccanico  
Refrigerazione: Statica • Gas: R600a  
Luce interna • Serratura con chiave  
4 rullini unidirezionali • Colore esterno: Bianco

Classe climatica: 4 • Thermostat: Meccanico  
Defrosting: Manual • Thermometer: Mechanic  
Refrigeration: Static • Gas: R600a  
Internal light • Key lock  
4 rollers • Body colour: White

	CHF 200	CHF 300	CHF 400	CHF 500
L x P x H (mm) W x D x H	890 x 650 x 850	1100 x 650 x 850	1390 x 650 x 850	1520 x 650 x 850
Potenza Power	87 W	130 W	160 W	210 W
Capacità lorda Gross capacity	180 lt	247 lt	318 lt	375 lt



### A RICHIESTA • OPTIONAL

Grafica su mobile e/o coperchio superiore • Kit ruote  
Graphic on body and/or top cover • Wheel kit

# CHF 700

-18°/-25° C



Termostato elettronico  
Electronic thermostat



Serratura con chiave  
Key lock

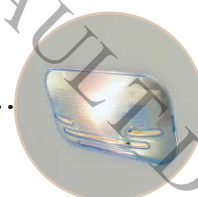

Luce interna  
Internal light



L x P x H: 1542 x 872 x 982 mm  
 Classe climatica: 7  
 Watt: 225 • Consumo energetico (24h): 2,70 kW  
 Capacità lorda: 628 lt • Capacità netta: 558 lt  
 Termostato: Elettronico • Sbrinamento: Manuale  
 Termometro: Elettronico • Refrigerazione: Statica  
 Gas: R290a • Luce interna • Serratura con chiave  
 4 rullini unidirezionali • Colore esterno: Bianco  
 Coperchio ad apertura compensata

W x D x H: 1542 x 872 x 982 mm  
 Climatic class: 7  
 Watt: 225 • Energy consumption (24h): 2,70 kW  
 Gross capacity: 628 lt • Net capacity: 558 lt  
 Thermostat: Electronic • Defrosting: Manual  
 Thermometer: Electronic • Refrigeration: Static  
 Gas: R290a • Internal light • Key lock  
 4 rollers • Body colour: White  
 Self-balancing cover



**A RICHIESTA • OPTIONAL**

Grafica su mobile e/o coperchio superiore • Kit ruote  
 Graphic on body and/or top cover • Wheel kit

# CHF 900 DD

-18°/-25° C



Termostato elettronico  
Electronic thermostat



Luce Interna  
Internal light



Doppia vasca  
Double tank

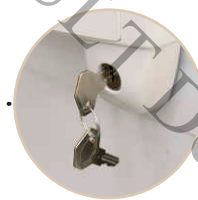
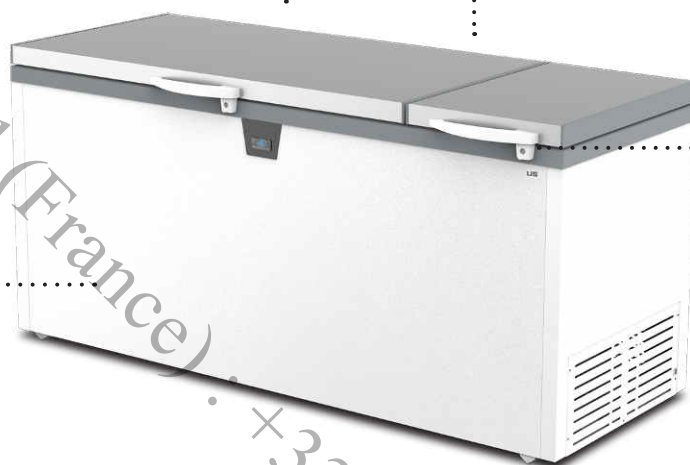

Serratura con chiave  
Key lock

L x P x H: 2055 x 872 x 983 mm

Classe climatica: 7

Watt: 235 • Consumo energetico (24h): 2,96 kW

Capacità lorda: 840 lt • Capacità netta: 777 lt

Termostato: Elettronico • Sbrinamento: Manuale

Termometro: Elettronico • Refrigerazione: Statica

Gas: R290a • Luce interna • Serratura con chiave

4 rullini unidirezionali • Colore esterno: Bianco

Coperchio ad apertura compensata

W x D x H: 2055 x 872 x 983 mm

Climatic class: 7

Watt: 235 • Energy consumption (24h): 2,96 kW

Gross capacity: 840 lt • Net capacity: 777 lt

Thermostat: Electronic • Defrosting: Manual

Thermometer: Electronic • Refrigeration: Static

Gas: R290a • Internal light • Key lock

4 rollers • Body colour: White

Self-balancing cover



## A RICHIESTA • OPTIONAL

Grafica su mobile e/o coperchio superiore • Kit ruote

Graphic on body and/or top cover • Wheel kit

# GOURMET 450 NA

-18°/-22° C



Griglia  
Shelf



Serratura con chiave  
Key lock



Termostato elettronico  
Electronic thermostat

L x P x H: 670 x 631 x 1995 mm  
 Classe climatica: 7 • Watt: 235  
 Consumo energetico (24h): 4,7 kW  
 Capacità lorda: 416 lt • Capacità netta: 320 lt  
 Termostato: Elettronico • Sbrinamento: Manuale  
 Termometro: Elettronico • Refrigerazione: Statica  
 con agitatore • 4 Gas: R290 • Serratura con chiave  
 2 piedini regolabili + 4 rullini  
 4 griglie (540 x 390 mm) + 1 di fondo (550 x 380 mm)  
 Colore esterno: Grigio silver  
 Valvola di compensazione per apertura facilitata della porta  
 Quantità massima vaschette 5 Lt (non fornite): N° 28

W x D x H: 670 x 631 x 1995 mm  
 Climatic class: 7 • Watt: 235  
 Energy consumption (24h): 4,7 kW  
 Gross capacity: 416 lt • Net capacity: 320 lt  
 Thermostat: Electronic • Defrosting: Manual  
 Thermometer: Electronic • Refrigeration: Static with fan  
 Gas: R290 • Key lock  
 2 adjustable feet + 4 rollers  
 4 shelf (540 x 390 mm) + 1 bottom shelf (550 x 380 mm)  
 Body colour: Silver Grey  
 Compensation valve for easier door opening  
 5 Lt bins max quantity (not included): N° 28



# GOURMET 700 NA

-18°/-22° C



CATERING  
ARMADI CONGELATORI • UPRIGHT FREEZERS



Griglia  
Shelf



Serratura con chiave  
Key lock



Termostato elettronico  
Electronic thermostat

L x P x H: 672 x 944 x 1995 mm  
Classe climatica: 7  
Watt: 275 • Consumo energetico (24h): 4,9 kW  
Capacità lorda: 651 lt • Capacità netta: 550 lt  
Termostato: Elettronico • Sbrinamento: Manuale  
Termometro: Elettronico • Refrigerazione: Statica  
Gas: R290 • Serratura con chiave  
2 piedini regolabili + 4 rullini  
4 griglie (527 x 683 mm) + 1 di fondo (515 x 660 mm)  
Colore esterno: Grigio silver  
Valvola di compensazione per apertura facilitata della porta  
Quantità massima vaschette 5 Lt (non fornite): N° 58

W x D x H: 672 x 944 x 1995 mm  
Climatic class: 7  
Watt: 275 • Energy consumption (24h): 4,9 kW  
Gross capacity: 651 lt • Net capacity: 550 lt  
Thermostat: Electronic • Defrosting: Manual  
Thermometer: Electronic • Refrigeration: Static  
Gas: R290 • Key lock  
2 adjustable feet + 4 rollers  
4 shelf (527 x 683 mm) + 1 bottom shelf (515 x 660 mm)  
Body colour: Silver Grey  
Compensation valve for easier door opening  
5 Lt bins max quantity (not included): N° 58



# AC 14 P

+2°/+8° C



Serratura con chiave  
Key lock



Termostato elettronico  
Electronic thermostat



L x P x H: 600 x 614 x 840 mm  
Classe climatica: 7 • Watt: 148 • Capacità lorda: 120 lt  
Capacità netta: 108 lt • Termostato: Elettronico  
Sbrinamento: Manuale • Termometro: Elettronico  
Refrigerazione: Statica • Gas: R290a  
Serratura con chiave • 2 piedini regolabili + 2 rullini  
2 griglie (500 x 400 mm)  
Colore esterno: Grigio silver

W x D x H: 600 x 614 x 840 mm  
Climatic class: 7 • Watt: 148 • Gross capacity: 120 lt  
Net capacity: 108 lt • Thermostat: Electronic  
Defrosting: Manual • Thermometer: Electronic  
Refrigeration: Statica • Gas: R290a  
Key lock • 2 adjustable feet + 2 rollers  
2 shelves (500 x 400 mm)  
Body colour: Silver Grey



# AC 42 P

+2°/+8° C



Serratura con chiave  
Key lock



Termostato elettronico  
Electronic thermostat



L x P x H: 600 x 614 x 1886 mm  
Classe climatica: 7 • Capacità lorda: 375 lt  
Watt: 174 • Consumo energetico (24h): 2,45 kW  
Capacità netta: 292 lt • Termostato: Elettronico  
Sbrinamento: Manuale • Termometro: Elettronico  
Refrigerazione: Statica • Gas: R290a  
Serratura con chiave • 2 piedini regolabili + 2 rullini  
4 griglie (500 x 400 mm)  
Colore esterno: Grigio silver

W x D x H: 600 x 614 x 1886 mm  
Climatic class: 7 • Gross capacity: 375 lt  
Watt: 174 • Energy consumption (24h): 2,45 kW  
Net capacity: 292 lt • Thermostat: Electronic  
Defrosting: Manual • Thermometer: Electronic  
Refrigeration: Statica • Gas: R290a  
Key lock • 2 adjustable feet + 2 rollers  
4 shelves (500 x 400 mm)



CATERING

ARMADI REFRIGERATI • UPRIGHT COOLERS

# AC 70 P

+2°/+8° C



Serratura con chiave  
Key lock



Termostato elettronico  
Electronic thermostat



L x P x H: 775 x 780 x 1886 mm  
Classe climatica: 7 • Capacità lorda: 610 lt  
Watt: 180 • Consumo energetico (24h): 2,78 kW  
Capacità netta: 510 lt • Termostato: Elettronico  
Sbrinamento: Manuale • Termometro: Elettronico  
Refrigerazione: Statica • Gas: R290a  
Serratura con chiave • 2 piedini regolabili + 4 rullini  
4 griglie (637 x 545 mm)  
Colore esterno: Grigio silver

W x D x H: 775 x 780 x 1886 mm  
Climatic class: 7 • Gross capacity: 610 lt  
Watt: 180 • Energy consumption (24h): 2,78 kW  
Net capacity: 510 lt • Thermostat: Electronic  
Defrosting: Manual • Thermometer: Electronic  
Refrigeration: Statica • Gas: R290a  
Key lock • 2 adjustable feet + 4 rollers  
4 shelves (637 x 545 mm)  
Body colour: Silver Grey



# AC 14 n

-18°/-25° C



Serratura con chiave  
Key lock



Termostato elettronico  
Electronic thermostat



L x P x H: 600 x 614 x 840 mm  
Classe climatica: 7 • Capacità lorda: 100 lt  
Watt: 86 • Consumo energetico (24h): 0,96 kW  
Capacità netta: 89 lt • Termostato: Elettronico  
Sbrinamento: Manuale • Termometro: Elettronico  
Refrigerazione: Statica • Gas: R290a  
Serratura con chiave • 2 piedini regolabili + 2 rullini  
2 griglie (500 x 400 mm)  
Colore esterno: Grigio silver

W x D x H: 610 x 614 x 840 mm  
Climatic class: 7 • Gross capacity: 100 lt  
Watt: 86 • Energy consumption (24h): 0,96 kW  
Net capacity: 89 lt • Thermostat: Electronic  
Defrosting: Manual • Thermometer: Electronic  
Refrigeration: Statica • Gas: R290a  
Key lock • 2 adjustable feet + 2 rollers  
2 shelves (500 x 400 mm)  
Body colour: Silver Grey



CATERING

ARMADI CONGELATORI • UPRIGHT FREEZERS

# AC 42 n

-18°/-25° C



Serratura con chiave  
Key lock



Termostato elettronico  
Electronic thermostat



Tél (France) : +33 (0)6 60 52 24 38

groupe-ruault.com

L x P x H: 600 x 614 x 1886 mm  
 Classe climatica: 7  
 Watt: 180 • Consumo energetico (24h): 2,57 kW  
 Capacità lorda: 360 lt • Capacità netta: 284 lt  
 Termostato: Elettronico  
 Sbrinamento: Manuale • Termometro: Elettronico  
 Refrigerazione: Statica • Gas: R290a  
 Serratura con chiave • 2 piedini regolabili + 2 rullini  
 Colore esterno: Grigio silver

W x D x H: 600 x 614 x 1886 mm  
 Climatic class: 7  
 Watt: 180 • Energy consumption (24h): 2,57 kW  
 Gross capacity: 360 lt Net capacity: 284 lt  
 Thermostat: Electronic  
 Defrosting: Manual • Thermometer: Electronic  
 Refrigeration: Statica • Gas: R290a  
 Key lock • 2 adjustable feet + 2 rollers  
 Body colour: Silver Grey



# AC 70 n

-18°/-25° C



Serratura con chiave  
Key lock



Termostato elettronico  
Electronic thermostat



L x P x H: 785 x 802 x 1886 mm  
Classe climatica: 7 • Capacità lorda: 610 lt  
Capacità netta: 512 lt • Termostato: Elettronico  
Sbrinamento: Manuale • Termometro: Elettronico  
Refrigerazione: Statica • Gas: R290a  
Serratura con chiave • 2 piedini regolabili + 4 rullini  
Colore esterno: Grigio silver

W x D x H: 785 x 802 x 1886 mm  
Climatic class: 7 • Gross capacity: 610 lt  
Net capacity: 512 lt • Thermostat: Electronic  
Defrosting: Manual • Thermometer: Electronic  
Refrigeration: Statica • Gas: R290a  
Key lock • 2 adjustable feet + 4 rollers  
Body colour: Silver Grey



CATERING

ARMADI CONGELATORI • UPRIGHT FREEZERS

## PERSONALIZZAZIONE - CUSTOMIZATION

Il Brand, la riconoscibilità di un'azienda, è fondamentale. Il frigorifero, con le sue ampie superfici, si presta bene a trasmettere tali valori nel Punto di Vendita.

UCINQUE è in grado di personalizzare qualsiasi tipo di apparecchio refrigerato in base alle esigenze dei clienti. Numerose le possibilità offerte da UCINQUE. Si va dalla personalizzazione di un singolo frigo a mezzo di film adesivi stampati in digitale a plastiche colorate e stampa digitale su lamiera, a pannelli con immagini in movimento, a veri e propri schermi video su cui proiettare i propri filmati ed all'IoT. In ogni caso, in base alle necessità della domanda UCINQUE è in grado di fornire la tecnologia più appropriata per implementare al meglio la comunicazione nel singolo Punto Vendita.



*Brand Recognition is essential for any company aspiring to stand out. Because of its broad customisable surfaces the cabinet is an excellent tool to convey Brand Identity at the Point of Sale. Ucinque has the capabilities to customize any type of refrigerated appliance according to customers' needs. There are manifold options offered by UCINQUE. They range from the personalization of a single cabinet through digitally printed stickers, colored plastics and digital printing on metal sheets, panels displaying moving pictures, screens playing videos, IoT. UCINQUE can recommend the best-suited technology to implement customers' communication at the Point of Sale.*

## ASSISTENZA TECNICA - TECHNICAL SUPPORT

UCINQUE propone prodotti con una limitata necessità di manutenzione nel tempo. Nonostante ciò U5 fornisce una garanzia 12 mesi. UCINQUE rilascia ampia garanzia di pronto intervento grazie alla propria rete di Service che copre l'intero territorio italiano ed alla disponibilità di tutti i ricambi necessari nei suoi magazzini. Oltre i confini Italiani UCINQUE ha sottoscritto accordi con i principali Service locali per garantire un servizio post-vendita rapido ed efficace, nonché scorte minime di ricambistica.

*UCINQUE is keen to supply refrigerators requiring limited maintenance over time. Nonetheless all products are supplied with a 12-month warranty. Under all circumstances, prompt after-sales attendance is ensured thanks to a service network active throughout the country and spare parts always available at Occimiano warehouse. Beyond the Italian borders UCINQUE has put in place agreements with the main local providers to guarantee a timely and effective after-sales service and buffer stock spares.*



## PARTI DI RICAMBIO - SPARE PARTS

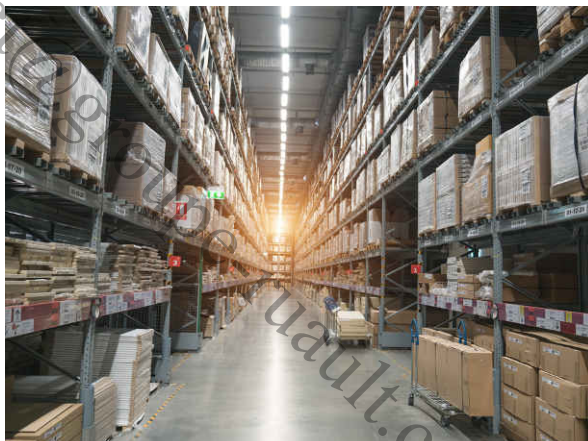

UCINQUE ha costantemente nei propri magazzini tutti i ricambi di cui possono abbisognare i suoi clienti ed i suoi Centri di Assistenza. Per un perfetto funzionamento nel tempo delle proprie attrezzature frigo Ucinque consiglia di utilizzare esclusivamente ricambi originali.

*UCINQUE has spares on hand regularly to meet customers' and ASP's requirements. In order to ensure a flawless cabinet performance, UCINQUE strongly advises to make use of original spare parts only, they are also covered by a 12-month warranty.*

MOD.	Dimensioni interne (L x P x H) <i>Pack dimension (W x D x H)</i>			Dimensioni imballo (L x P x H) <i>Pack dimension (W x D x H)</i>			m <sup>3</sup>	Kg
	L	P	H	L	P	H		
	mm			mm				
CX 50	262	280	370	380	450	510	0,09	16,5
CX 68	375	365	435	490	540	545	0,09	25
CX 98	360	360	580	485	530	725	0,19	26
CAN 50	Ø 350		502	460	460	900	0,19	25
CAN 65	Ø 440		495	600	600	980	0,35	33,5
POP 365 P	370	390	435	595	860	1230	0,62	38
RB 300	970	470	650	1120	720	930	0,75	47
RB 400	1200	470	650	1360	720	930	0,91	51
SELF BAR 1	510	330	745	655	560	950	0,33	55
SELF BAR 2	800	330	745	955	560	950	0,56	72
SELF BAR 3	1240	330	745	1390	560	950	0,83	90
FV 200 S	320	450	1452	460	655	2010	0,60	75
FV 200 S BLACK	320	450	1452	460	655	2010	0,60	75
FV 300 S	372	580	1452	520	710	1990	0,73	80
FV 300 S BLACK	372	580	1452	520	710	1990	0,73	80
FV 300 S RETRO'	372	580	1452	520	760	2200	0,86	85
FV 390.1 CL	510	470	1555	610	620	2200	0,83	83
FV 390.1 CL BLACK	510	470	1555	610	620	2200	0,83	83
KAYO 14 P	520	470	610	635	650	1006	0,42	43
KAYO 42 EVO	520	470	1655	635	650	1980	0,82	85
KAYO 42 CL EVO	520	470	1655	635	650	2130	0,88	88
KAYO 42 BLACK EVO	520	470	1655	635	650	1980	0,82	85
KAYO 42 CL BLACK EVO	520	470	1655	635	650	2130	0,88	88
KAYO 42 PV	520	470	1655	635	650	2032	0,84	85
KAYO 70 P	655	630	1425	810	820	2052	1,36	97
FV 110 S	910	530	1340	1170	740	2145	1,85	170
CW 40	410	410	735	520	500	920	0,33	36
CW 85	520	460	1360	550	700	1340	0,51	62
CW 400	520	470	1655	635	650	2000	0,82	85
CW 400 MT	520	470	1655	635	650	2000	0,80	85
CW 400 INOX	520	470	1655	635	650	2000	0,80	85
WINE CLASS	520	470	1655	635	650	2000	0,83	85
WINE CLASS S	520	470	1655	635	650	2000	0,83	96
CW 400 L	520	470	1655	670	650	2050	0,87	131
CW 800 L	520 + 520	470	1655	1335	695	2050	1,90	236

MOD.	Dimensioni interne (L x P x H) <i>Pack dimension (W x D x H)</i>			Dimensioni imballo (L x P x H) <i>Pack dimension (W x D x H)</i>			m <sup>3</sup>	Kg
	L	P	H	L	P	H		
	mm			mm				
CUBE	450	420	440	605	572	570	0,20	44
IQ	380	340	608	560	545	1140	0,34	55
IQ GLAMOUR	380	340	608	560	545	1140	0,34	70
POP 50	370	390	193	565	820	580	0,21	33
POP 60	545	390	193	810	730	580	0,34	37
POP 365 50	370	390	435	595	860	1230	0,62	49
JOKER	735	190	434	905	400	970	0,35	35
KAPPA 100	435	555	570	625	770	890	0,43	52
KAPPA 200	656	550	600	880	770	890	0,60	56
CIS 160 AT	665	540	600	740	760	950	0,53	49
CIS 260 AT	990	540	600	1070	770	950	0,78	64
CIS 360 AT	1260	540	600	1335	770	950	0,98	76
CIS 460 AT	1530	540	600	1610	770	950	1,18	89
CIS 160 VT	665	540	600	740	760	950	0,53	49
CIS 260 VT	990	540	600	1070	770	950	0,78	64
CIS 360 VT	1260	540	600	1335	760	950	0,96	76
CIS 460 VT	1530	540	600	1610	770	950	1,16	88
CIS 160 CC	665	540	600	740	760	950	0,53	49
CIS 260 CC	990	540	600	1070	770	950	0,78	64
CIS 360 CC	1260	540	600	1335	760	950	0,96	76
CIS 460 CC	1530	540	600	1610	770	950	1,18	89
VINTAGE 200 VT	850	500	610	1130	785	1070	0,93	66
VINTAGE 300 VT	1100	500	610	1380	785	1070	1,14	84
BMAX 400 AT AT	1080	560	760	1330	780	1060	1,10	100
BMAX 680 AT AT	1330	560	760	1580	780	1080	1,33	110
BMAX 680 VT AT	1340	610	863	1559	829	1128	1,45	110
BMAX 680 CC AT	1340	610	863	1559	829	1128	1,45	108
BMAX 400 GLAMOUR	1330	560	760	1580	780	1080	1,33	116
KRYO 42 NV	480	464	1615	635	650	2052	0,84	122
FROST 180 NS	280	440	1412	460	660	1980	0,60	84
FROST 250 NS	322	555	1412	520	710	1980	0,73	103
FROST GLAMOUR 250 NS	322	555	1412	520	710	1890	0,73	133
FROST 250 NV SD	322	555	1412	520	710	1980	0,73	112
FROST 280 NS SD	322	555	1412	520	710	1980	0,73	102
FROST 350 NS	480	490	1373	670	670	2000	0,89	112
FROST 350 NS SD	480	490	1373	670	670	2000	0,89	111
FROST GLAMOUR 350 NS	480	490	1373	670	670	2000	0,89	140
FROST 400 NS	550	495	1528	705	670	2160	1,00	126
FROST 400 NS SD	550	495	1528	705	670	2160	1,00	127
FROST GLAMOUR 400 NS	550	495	1528	705	670	2160	1,02	146
FROST 400 NV	550	445	1334	705	670	2160	1,02	126
FROST 400 NV SD	550	445	1334	705	670	2160	1,02	125

MOD.	Dimensioni interne (L x P x H) <i>Pack dimension (W x D x H)</i>			Dimensioni imballo (L x P x H) <i>Pack dimension (W x D x H)</i>			m <sup>3</sup>	Kg
	L	P	H	L	P	H		
	mm			mm				
FROST 350 PS	480	490	1373	640	670	2000	0,85	112
FROST 350 PS SD	480	490	1373	640	670	2000	0,85	102
FROST GLAMOUR 350 PS	480	490	1373	640	670	2000	0,85	117
FROST 400 PS	550	500	1350	705	670	2150	1,00	119
FROST 400 PS SD	550	500	1350	705	670	2150	1,00	118
VERTICAL VINTAGE 350	480	490	1373	670	670	2000	1,06	132
VERTICAL VINTAGE 400	550	495	1411	705	670	2250	1,06	148
GLAMOUR TOWER	550	495	1349	705	720	2156	1,09	180
TWIN 40	550(P)/550(N)	494(P)/494(N)	766(P)/662(N)	705	670	2145	1,01	136
TRECARAPINE	855	390	415	1080	641	1078	0,74	90
VIA VENETO 4C	600	500	610	880	785	1070	0,77	70
VIA VENETO 6C	850	500	610	1130	785	1070	0,95	82
VIA VENETO 8C	1100	500	610	1380	785	1070	1,16	89
VIA VENETO COMBI 4C	600	500	610	880	785	1070	0,77	70
VIA VENETO COMBI 6C	850	500	610	1130	785	1070	0,95	82
VIA VENETO COMBI 8C	1100	500	610	1380	785	1070	1,16	89
VINTAGE SCOOPING 5V	850	500	610	1130	785	1070	0,95	82
VINTAGE SCOOPING 6V	1100	500	610	1380	785	1070	1,16	89
EVOQUE 7	--	--	--	1140	930	1260	1,68	215
EVOQUE 10	--	--	--	1480	1000	1260	1,86	227
EVOQUE 13	--	--	--	1860	1000	1260	2,34	251

contact@groupe-ruault.com

MOD.	Dimensioni interne (L x P x H) <i>Internal dimensions (W x D x H)</i>			Dimensioni imballo (L x P x H) <i>Pack dimension (W x D x H)</i>			m <sup>3</sup>	Kg
	L	P	H	L	P	H		
	mm			mm				
SYSON 100	950	500	1200	1100	780	2165	1,66	184
SYSON 130	1250	500	1200	1330	780	2165	2,28	259
SYSON 160	1450	500	1200	1610	780	2165	2,71	390
EVO 150 GT	1350	775	470	1600	1010	900	1,45	83
EVO 200 GT	1850	775	470	2100	1010	900	1,91	98
EVO 250 GT	2350	775	470	2580	1010	900	2,35	165
EVO 150 GT HGD	1350	775	470	1600	1010	900	1,45	83
EVO 200 GT HGD	1850	775	470	2100	1010	900	1,91	98
EVO 250 GT HGD	2350	775	470	2580	1010	900	2,35	165
PROMO 75	630	420	300	860	760	1015	0,66	47

MOD.	Dimensioni interne (L x P x H) <i>Internal dimensions (W x D x H)</i>			Dimensioni imballo (L x P x H) <i>Pack dimension (W x D x H)</i>			m <sup>3</sup>	Kg
	L	P	H	L	P	H		
	mm			mm				
CHF 200	745	472	684	920	710	930	0,61	39
CHF 300	962	472	684	1120	720	930	0,75	47
CHF 400	1192	472	684	1360	720	930	0,91	51
CHF 500	1382	472	684	1580	730	900	1,04	57
CHF 700	1385	626	740	1630	935	1210	1,84	102
CHF 900 DD	1430 + 400	626	740	2150	935	1210	2,43	130
GOURMET 450 NA	550	435	1528	670	680	2150	0,98	134
GOURMET 700 NA	550	740	1528	705	725	2150	1,10	134
AC 14 P	520	470	610	635	650	1006	0,42	47
AC 42 P	520	470	1655	635	650	1980	0,82	85
AC 70 P	655	630	1615	810	820	2052	1,36	93
AC 14 N	520	470	610	635	650	1006	0,42	48
AC 42 N	520	470	1655	635	650	1980	0,82	85
AC 70 N	655	630	1615	880	820	2052	1,36	93

Votre distributeur : RUVAULT Design

Tél (France) : +33 (0)6 60 52 24 38

[contact@groupe-ruault.com](mailto:contact@groupe-ruault.com)

Votre distributeur : RUAULT Design

Tél (France) : +33 (0)6 60 52 24 38

[contact@groupe-ruault.com](mailto:contact@groupe-ruault.com)

Votre distributeur : RUAULT Design



Professional Refrigeration

UCINQUE S.R.L

VIA CASALE N° 17/A  
15040 OCCIMIANO (AL) - ITALY

TEL +39 0142 578042

WWW.UCINQUE.IT



contact@groupe-ruault.com

COD: EU50639

Ucinque Srl si riserva il diritto di modificare/migliorare i suoi prodotti senza alcun preavviso.  
Le foto rappresentate sono puramente illustrative; per le caratteristiche fare riferimento ai dati tecnici.

*Ucinque Srl reserves the right to modify/improve its products without notice.  
The pictures here printed are purely and only for description purposes, please refer to technical data for product features.*